



STA013 STA013B STA013T

MPEG 2.5 LAYER III AUDIO DECODER

- SINGLE CHIP MPEG2 LAYER 3 DECODER SUPPORTING:
 - All features specified for Layer III in ISO/IEC 11172-3 (MPEG 1 Audio)
 - All features specified for Layer III in ISO/IEC 13818-3.2 (MPEG 2 Audio)
 - Lower sampling frequencies syntax extension, (not specified by ISO) called MPEG 2.5
- DECODES LAYER III STEREO CHANNELS, DUAL CHANNEL, SINGLE CHANNEL (MONO)
- SUPPORTING ALL THE MPEG 1 & 2 SAMPLING FREQUENCIES AND THE EXTENSION TO MPEG 2.5:
48, 44.1, 32, 24, 22.05, 16, 12, 11.025, 8 KHz
- ACCEPTS MPEG 2.5 LAYER III ELEMENTARY COMPRESSED BITSTREAM WITH DATA RATE FROM 8 Kbit/s UP TO 320 Kbit/s
- DIGITAL VOLUME CONTROL
- DIGITAL BASS & TREBLE CONTROL
- SERIAL BITSTREAM INPUT INTERFACE
- ANCILLARY DATA EXTRACTION VIA I2C INTERFACE.
- SERIAL PCM OUTPUT INTERFACE (I²S AND OTHER FORMATS)
- PLL FOR INTERNAL CLOCK AND FOR OUTPUT PCM CLOCK GENERATION
- LOW POWER CONSUMPTION:
85mW AT 2.4V
- CRC CHECK AND SYNCHRONISATION ERROR DETECTION WITH SOFTWARE INDICATORS
- I²C CONTROL BUS
- LOW POWER 3.3V CMOS TECHNOLOGY
- 10 MHz, 14.31818 MHz, OR 14.7456 MHz EXTERNAL INPUT CLOCK OR BUILT-IN INDUSTRY STANDARD XTAL OSCILLATOR DIFFERENT FREQUENCIES MAY BE SUPPORTED UPON REQUEST TO STM

APPLICATIONS

- PC SOUND CARDS
- MULTIMEDIA PLAYERS

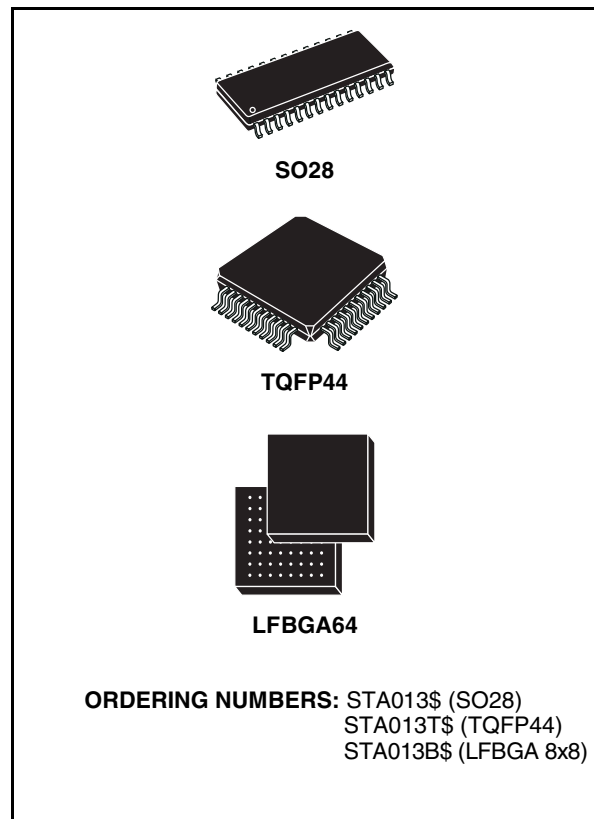

DESCRIPTION

The STA013 is a fully integrated high flexibility MPEG Layer III Audio Decoder, capable of decoding Layer III compressed elementary streams, as specified in MPEG 1 and MPEG 2 ISO standards. The device decodes also elementary streams compressed by using low sampling rates, as specified by MPEG 2.5.

STA013 receives the input data through a Serial Input Interface. The decoded signal is a stereo, mono, or dual channel digital output that can be sent directly to a D/A converter, by the PCM Output Interface. This interface is software programmable to adapt the STA013 digital output to the most common DACs architectures used on the market.

The functional STA013 chip partitioning is described in Fig.1.

Figure 1. Block Diagram: MPEG 2.5 Layer III Decoder Hardware Partitioning.

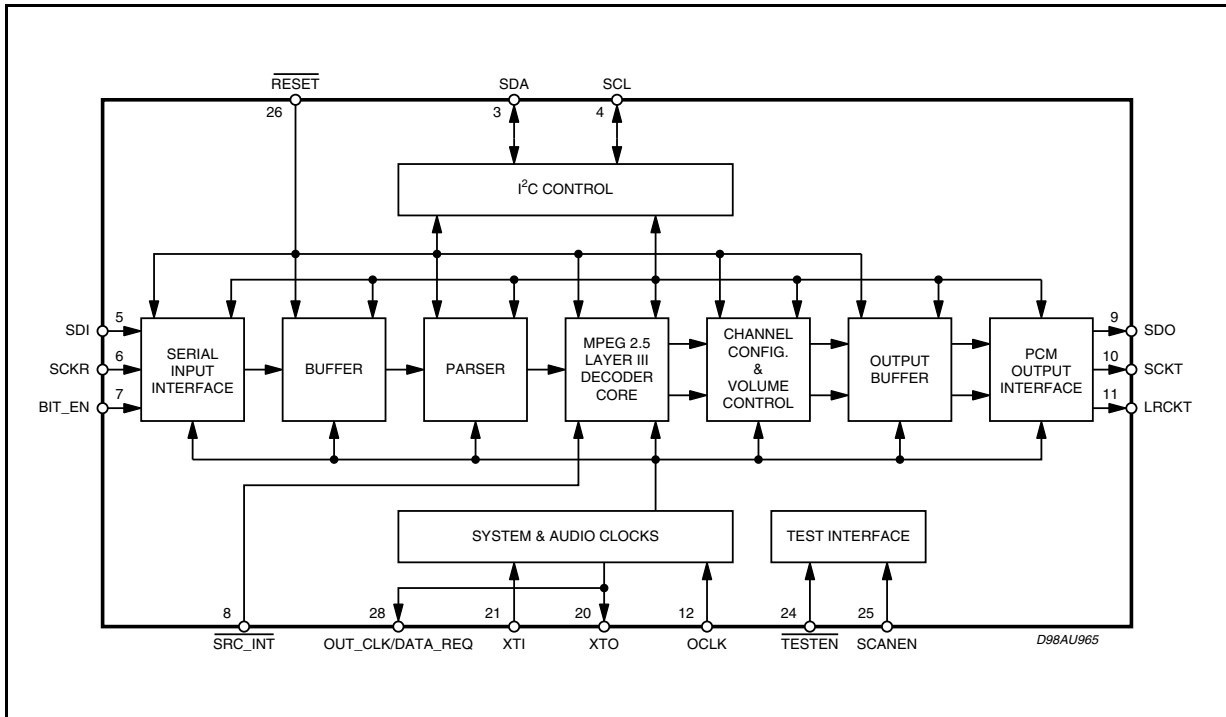

THERMAL DATA

Symbol	Parameter	Value	Unit
R _{th j-amb}	Thermal resistance Junction to Ambient	85	°C/W

ABSOLUTE MAXIMUM RATINGS

Symbol	Parameter	Value	Unit
V _{DD}	Power Supply	-0.3 to 4	V
V _i	Voltage on Input pins	-0.3 to V _{DD} +0.3	V
V _O	Voltage on output pins	-0.3 to V _{DD} +0.3	V
T _{stg}	Storage Temperature	-40 to +150	°C
T _{oper}	Operative ambient temp	-40 to +85 (*)	°C
T _j	Operating Junction Temperature	-40 to 125	°C

(*) guaranteed by design.

Figure 2. Pin Connection

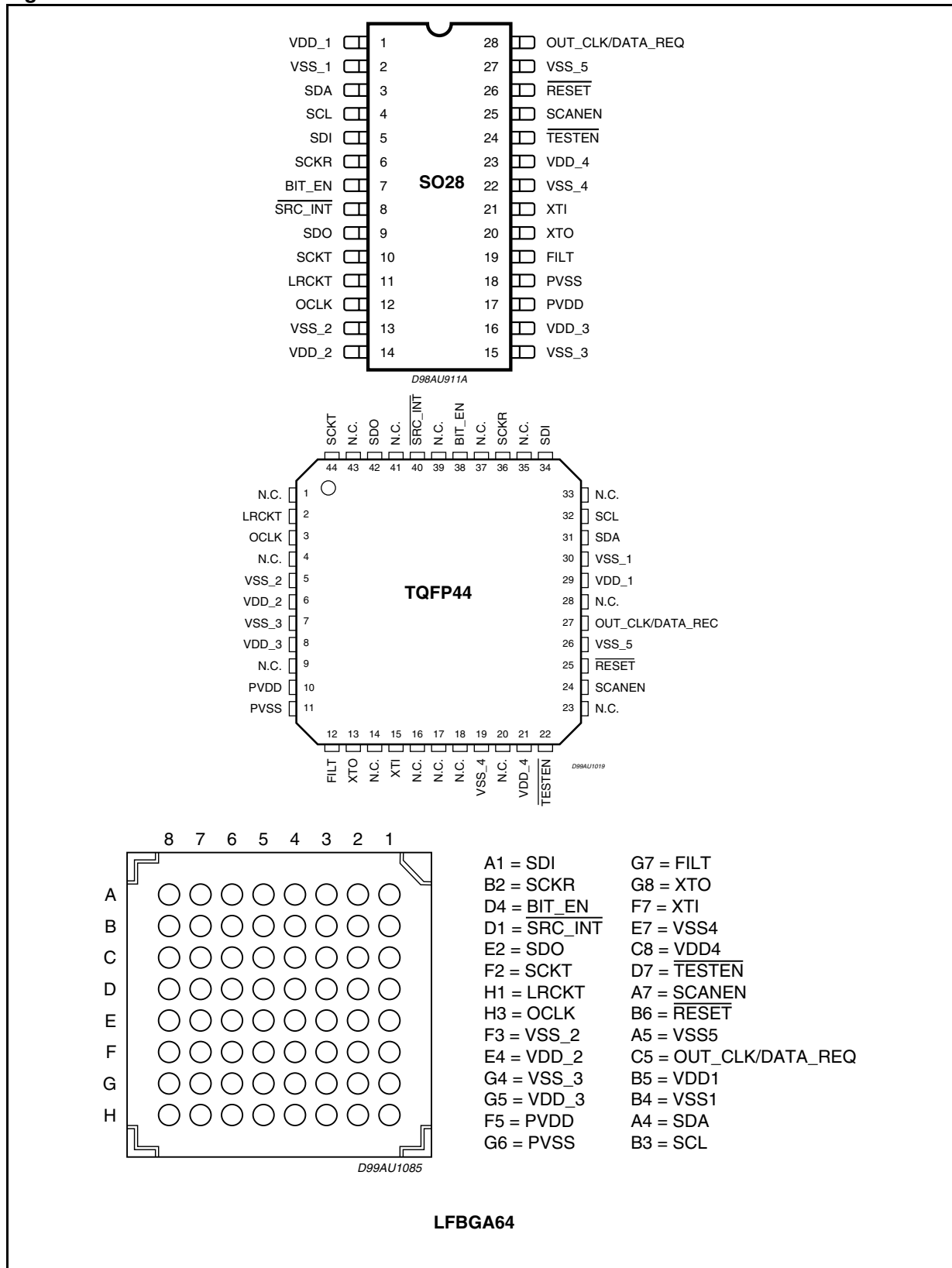

STA013 - STA013B - STA013T

PIN DESCRIPTION

SO28	TQFP44	LFBGA64	Pin Name	Type	Function	PAD Description
1	29	B5	VDD_1		Supply Voltage	
2	30	B4	VSS_1		Ground	
3	31	A4	SDA	I/O	i ² C Serial Data + Acknowledge	CMOS Input Pad Buffer CMOS 4mA Output Drive
4	32	B3	SCL	I	i ² C Serial Clock	CMOS Input Pad Buffer
5	34	A1	SDI	I	Receiver Serial Data	CMOS Input Pad Buffer
6	36	B2	SCKR	I	Receiver Serial Clock	CMOS Input Pad Buffer
7	38	D4	BIT_EN	I	Bit Enable	CMOS Input Pad Buffer with pull up
8	40	D1	$\overline{\text{SRC_INT}}$	I	Interrupt Line For S.R. Control	CMOS Input Pad Buffer
9	42	E2	SDO	O	Transmitter Serial Data (PCM Data)	CMOS 4mA Output Drive
10	44	F2	SCKT	O	Transmitter Serial Clock	CMOS 4mA Output Drive
11	2	H1	LRCKT	O	Transmitter Left/Right Clock	CMOS 4mA Output Drive
12	3	H3	OCLK	I/O	Oversampling Clock for DAC	CMOS Input Pad Buffer CMOS 4mA Output Drive
13	5	F3	VSS_2		Ground	
14	6	E4	VDD_2		Supply Voltage	
15	7	G4	VSS_3		Ground	
16	8	G5	VDD_3		Supply Voltage	
17	10	F5	PVDD		PLL Power	
18	11	G6	PVSS		PLL Ground	
19	12	G7	FILT	O	PLL Filter Ext. Capacitor Conn.	
20	13	G8	XTO	O	Crystal Output	CMOS 4mA Output Drive
21	15	F7	XTI	I	Crystal Input (Clock Input)	Specific Level Input Pad (see paragraph 2.1)
22	19	E7	VSS_4		Ground	
23	21	C8	VDD_4		Supply Voltage	
24	22	D7	$\overline{\text{TESTEN}}$	I	Test Enable	CMOS Input Pad Buffer with pull up
25	24	A7	SCANEN	I	Scan Enable	CMOS Input Pad Buffer
26	25	B6	$\overline{\text{RESET}}$	I	System Reset	CMOS Input Pad Buffer with pull up
27	26	A5	VSS_5		Ground	
28	27	C5	OUT_CLK/ DATA_REQ	O	Buffered Output Clock/ Data Request Signal	CMOS 4mA Output Drive

Note: SRC_INT signal is used by STA013 internal software in Broadcast Mode only; in Multimedia mode SRC_INT must be connected to V_{DD}. In functional mode TESTEN must be connected to VDD, SCANEN to ground.

1. ELECTRICAL CHARACTERISTICS: $V_{DD} = 2.7V \pm 0.3V$; $T_{amb} = 0$ to $70^{\circ}C$; $R_g = 50\Omega$ unless otherwise specified

DC OPERATING CONDITIONS

Symbol	Parameter	Value
V_{DD}	Power Supply Voltage	2.4 to 3.6V

GENERAL INTERFACE ELECTRICAL CHARACTERISTICS

Symbol	Parameter	Test Condition	Min.	Typ.	Max.	Unit	Note
I_{iL}	Low Level Input Current Without pull-up device	$V_i = 0V$	-10		10	A	1
I_{iH}	High Level Input Current Without pull-up device	$V_i = V_{DD} = 3.6V$	-10		10	A	1
V_{esd}	Electrostatic Protection	Leakage < 1 A	2000			V	2

Note 1: The leakage currents are generally very small, < 1nA. The value given here is a maximum that can occur after an electrostatic stress on the pin.

Note 2: Human Body Model.

DC ELECTRICAL CHARACTERISTICS

Symbol	Parameter	Test Condition	Min.	Typ.	Max.	Unit	Note
V_{iL}	Low Level Input Voltage				$0.2 \cdot V_{DD}$	V	
V_{iH}	High Level Input Voltage		$0.8 \cdot V_{DD}$			V	
V_{oL}	Low Level Output Voltage	$I_{oL} = X_{ma}$			0.4V	V	1, 2
V_{oH}	High Level Output Voltage		$0.85 \cdot V_{DD}$			V	1, 2

Note 1: Takes into account 200mV voltage drop in both supply lines.

Note 2: X is the source/sink current under worst case conditions and is reflected in the name of the I/O cell according to the drive capability.

Symbol	Parameter	Test Condition	Min.	Typ.	Max.	Unit	Note
I_{pu}	Pull-up current	$V_i = 0V$; pin numbers 7, 24 and 26; $V_{DD} = 3V$	-25	-66	-125	A	1
R_{pu}	Equivalent Pull-up Resistance			50		$k\Omega$	

Note 1: Min. condition: $V_{DD} = 2.4V$, $125^{\circ}C$ Min process

Max. condition: $V_{DD} = 3.6V$, $-20^{\circ}C$ Max.

POWER DISSIPATION

Symbol	Parameter	Test Condition	Min.	Typ.	Max.	Unit	Note
PD	Power Dissipation @ $V_{DD} = 3V$	Sampling_freq ≤ 24 kHz		76		mW	
		Sampling_freq ≤ 32 kHz		79		mW	
		Sampling_freq ≤ 48 kHz		85		mW	

Figure 3. Test Circuit

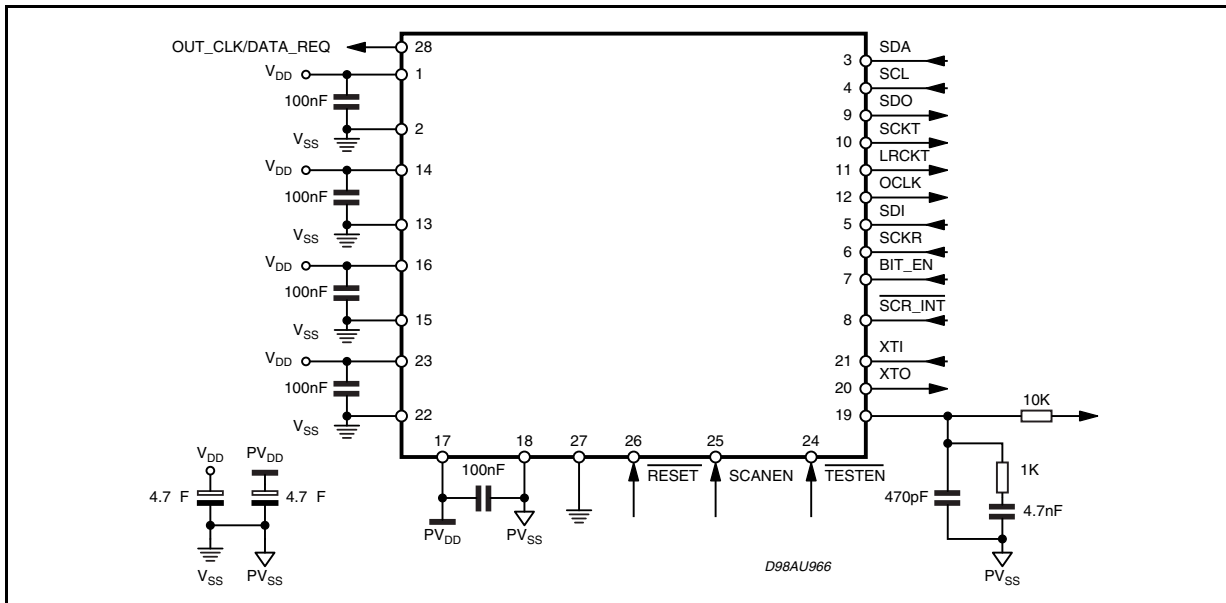
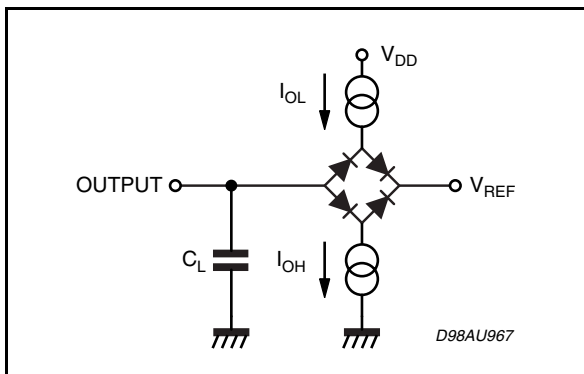

Figure 4. Test Load Circuit



Test Load

Output	IoL	IoH	CL	VREF
SDA	1mA		100pF	3.6V
Other Outputs	100 A	100 A	100pF	1.5V

2. FUNCTIONAL DESCRIPTION

2.1 - Clock Signal

The STA013 input clock is derived from an external source or from a industry standard crystal oscillator, generating input frequencies of 10, 14.31818 or 14.7456 MHZ.

Other frequencies may be supported upon request to STMicroelectronics. Each frequency is supported by downloading a specific configuration file, provided by STM

XTI is an input Pad with specific levels.

Symbol	Parameter	Test Condition	Min.	Typ.	Max.	Unit
V _{IL}	Low Level Input Voltage				V _{DD} -1.8	V
V _{IH}	High Level Input Voltage		V _{DD} -0.8			V

CMOS compatibility

The XTI pad low and high levels are CMOS compatible; XTI pad noise margin is better than typical CMOS pads.

TTL compatibility

The XTI pad low level is compatible with TTL while the high level is not compatible (for example if V_{DD} = 3V TTL min high level = 2.0V while XTI min high level = 2.2V)

Figure 5. MPEG Decoder Interfaces.

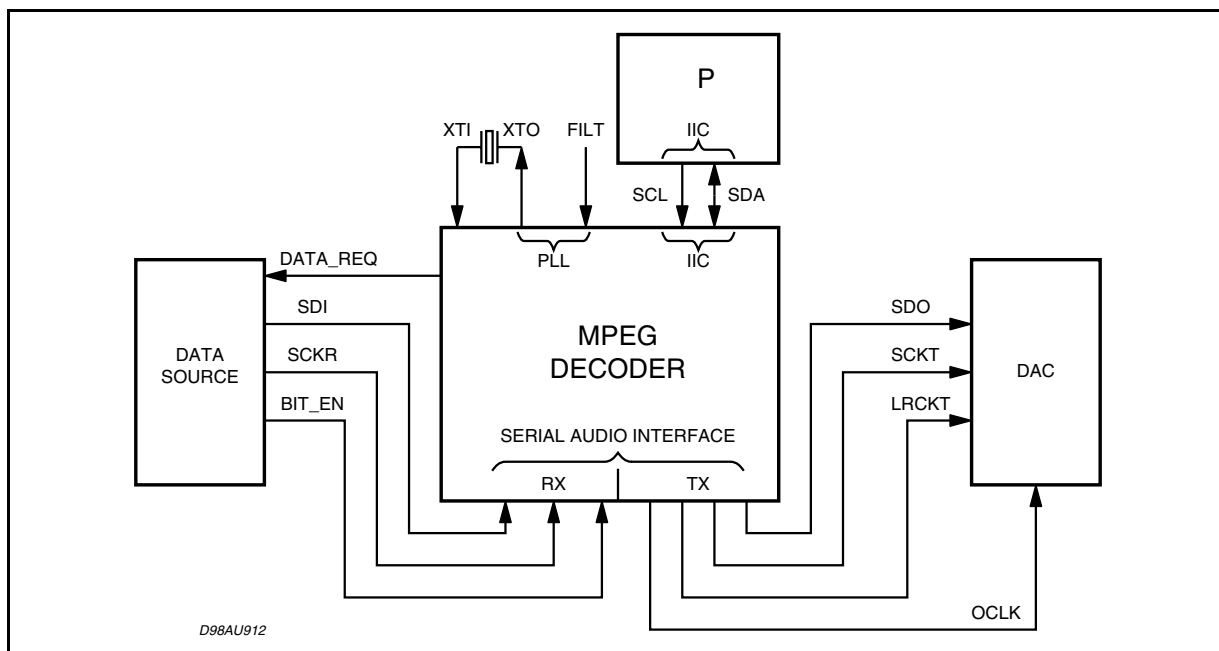
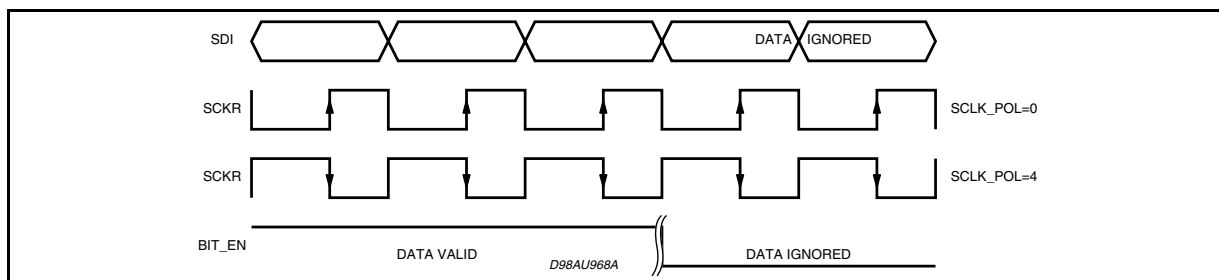

Figure 6. Serial Input Interface Clocks



2.2 - Serial Input Interface

STA013 receives the input data (MSB first) through the Serial Input Interface (Fig.5). It is a serial communication interface connected to the SDI (Serial Data Input) and SCKR (Receiver Serial Clock).

The interface can be configured to receive data sampled on both rising and falling edge of the SCKR clock.

The BIT_EN pin, when set to low, forces the bit-stream input interface to ignore the incoming data. For proper operation Bit-EN line should be toggled only when SCKR is stable low (for both SCLK_POL configuration) The possible configurations are described in Fig. 6.

2.3 - PLL & Clock Generator System

When STA013 receives the input clock, as described in Section 2.1, and a valid layer III input bit stream, the internal PLL locks, providing to the DSP Core the master clock (DCLK), and to the Audio Output Interface the nominal frequencies of the incoming compressed bit stream. The STA013 PLL block diagram is described in Figure 7.

The audio sample rates are obtained dividing the oversampling clock (OCLK) by software programmable factors. The operation is done by STA013 embedded software and it is transparent to the user.

The STA013 PLL can drive directly most of the commercial DACs families, providing an oversampling clock, OCLK, obtained dividing the VCO frequency with a software programmable dividers.

Figure 7. PLL and Clocks Generation System

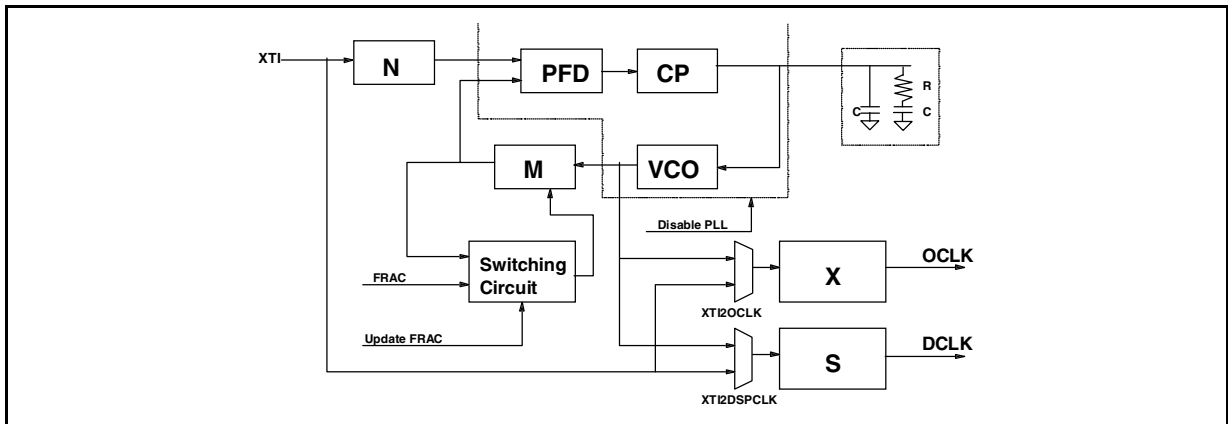

2.4 - PCM Output Interface

The decoded audio data are output in serial PCM format. The interface consists of the following signals:

- SDO PCM Serial Data Output
 - SCKT PCM Serial Clock Output
 - LRCLK Left/Right Channel Selection Clock
- The output samples precision is selectable from

16 to 24 bits/word, by setting the output precision with PCMCONF (16, 18, 20 and 24 bits mode) register. Data can be output either with the most significant bit first (MS) or least significant bit first (LS), selected by writing into a flag of the PCMCONF register.

Figure 8 gives a description of the several STA013 PCM Output Formats.

The sample rates set decoded by STA013 is described in Table 1.

Figure 8. PCM Output Formats

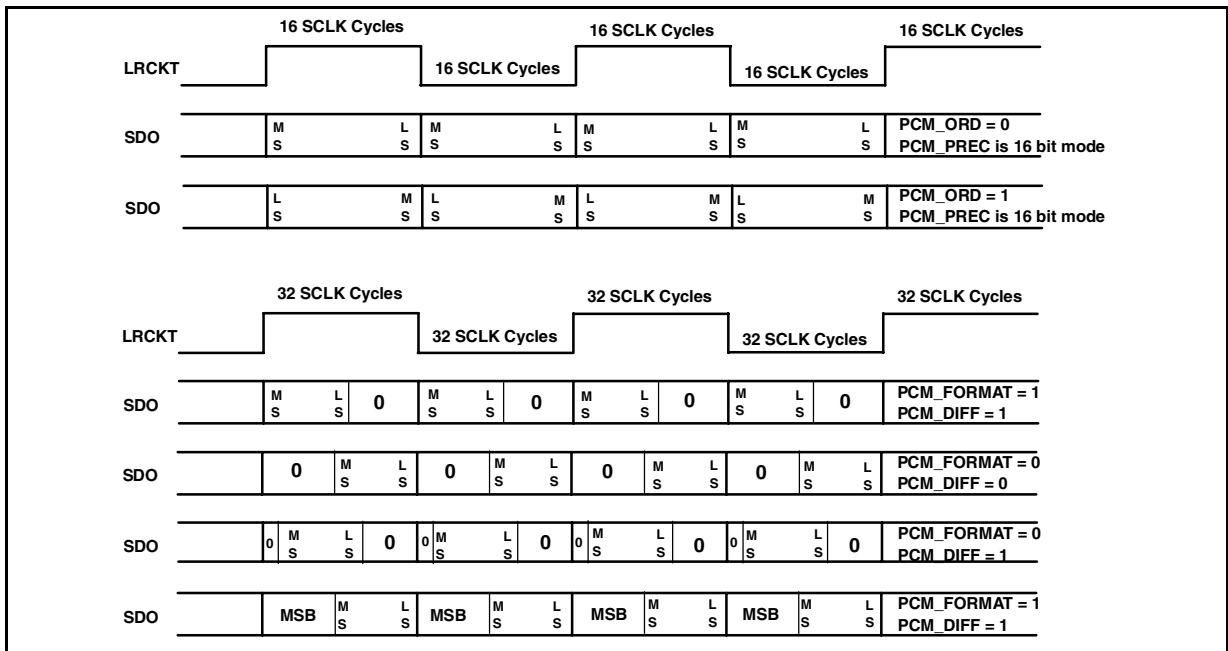

Table 1: MPEG Sampling Rates (KHz)

MPEG 1	MPEG 2	MPEG 2.5
48	24	12
44.1	22.05	11.025
32	16	8

2.5 - STA013 Operation Mode

The STA013 can work in two different modes, called Multimedia Mode and Broadcast Mode. In **Multimedia Mode**, STA013 decodes the incoming bitstream, acting as a master of the data communication from the source to itself. This control is done by a specific buffer management, controlled by STA013 embedded software.

The data source, by monitoring the DATA_REQ line, send to STA013 the input data, when the signal is high (default configuration). The communication is stopped when the DATA_REQ line is low.

In this mode the fractional part of the PLL is disabled and the audio clocks are generated at nominal rates. Fig. 9 describes the default DATA_REQ signal behaviour.

Programming STA013 it is possible to invert the polarity of the DATA_REQ line (register REQ_POL).

Figure 9.

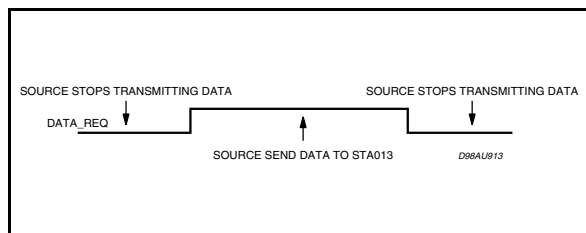

In **Broadcast Mode**, STA013 works receiving a bitstream with the input speed regulated by the source. In this configuration the source has to guarantee that the bitrate is equivalent to the nominal bitrate of the decoded stream.

To compensate the difference between the nominal and the real sampling rates, the STA013 embedded software controls the fractional PLL operation. Portable or Mobile applications need normally to operate in Broadcast Mode. In both modes the MPEG Synchronisation is automatic and transparent to the user. To operate in Multimedia mode, the STA013, pin nr. 8, SCR-INT must be connected to VDD on the application board.

2.6 - STA013 Decoding States

There are three different decoder states: **Idle**, **Init**, and **Decode**. Commands to change the decoding states are described in the STA013 I²C registers description.

Idle Mode

In this mode the decoder is waiting for the RUN command. This mode should be used to initialise

the configuration register of the device. The DAC connected to STA013 can be initialised during this mode (set MUTE to 1).

PLAY	MUTE	Clock State	PCM Output
X	0	Not Running	0
X	1	Running	0

Init Mode

"PLAY" and "MUTE" changes are ignored in this mode. The internal state of the decoder will be updated only when the decoder changes from the state "init" to the state "decode". The "init" phase ends when the first decoded samples are at the output stage of the device.

Decode Mode

This mode is completely described by the following table:

PLAY	MUTE	Clock State	PCM Output	Decoding
0	0	Not Running	0	No
0	1	Running	0	No
1	0	Running	Decoded Samples	Yes
1	1	Running	0	Yes

3 - I²C BUS SPECIFICATION

The STA013 supports the I²C protocol. This protocol defines any device that sends data on to the bus as a transmitter and any device that reads the data as a receiver. The device that controls the data transfer is known as the master and the others as the slave. The master always starts the transfer and provides the serial clock for synchronisation. The STA013 is always a slave device in all its communications.

3.1 - COMMUNICATION PROTOCOL

3.1.0 - Data transition or change

Data changes on the SDA line must only occur when the SCL clock is low. SDA transition while the clock is high are used to identify START or STOP condition.

3.1.1 - Start condition

START is identified by a high to low transition of the data bus SDA signal while the clock signal SCL is stable in the high state.

A START condition must precede any command for data transfer.

3.1.2 - Stop condition

STOP is identified by low to high transition of the data bus SDA signal while the clock signal SCL is stable in the high state. A STOP condition terminates communications between STA013 and the bus master.

3.1.3 - Acknowledge bit

An acknowledge bit is used to indicate a successful data transfer. The bus transmitter, either master or slave, releases the SDA bus after sending 8 bit of data.

During the 9th clock pulse the receiver pulls the SDA bus low to acknowledge the receipt of 8 bits of data.

3.1.4 - Data input

During the data input the STA013 samples the SDA signal on the rising edge of the clock SCL.

For correct device operation the SDA signal has to be stable during the rising edge of the clock and the data can change only when the SCL line is low.

3.2 - DEVICE ADDRESSING

To start communication between the master and the STA013, the master must initiate with a start condition. Following this, the master sends onto the SDA line 8 bits (MSB first) corresponding to the device select address and read or write mode.

The 7 most significant bits are the device address identifier, corresponding to the I²C bus definition. For the STA013 these are fixed as 1000011.

The 8th bit (LSB) is the read or write operation RW, this bit is set to 1 in read mode and 0 for write mode. After a START condition the STA013 identifies on the bus the device address and, if a match is found, it acknowledges the identification on SDA bus during the 9th bit time. The following byte after the device identification byte is the internal space address.

3.3 - WRITE OPERATION (see fig. 10)

Following a START condition the master sends a device select code with the RW bit set to 0.

The STA013 acknowledges this and waits for the byte of internal address.

After receiving the internal bytes address the STA013 again responds with an acknowledge.

3.3.1 - Byte write

In the byte write mode the master sends one data byte, this is acknowledged by STA013. The master then terminates the transfer by generating a STOP condition.

3.3.2 - Multibyte write

The multibyte write mode can start from any internal address. The transfer is terminated by the master generating a STOP condition.

Figure 10. Write Mode Sequence

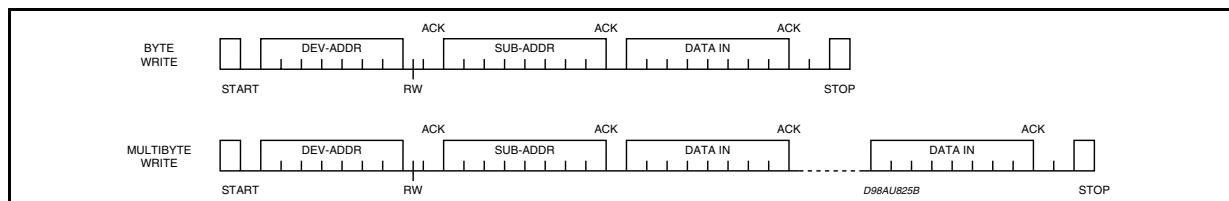
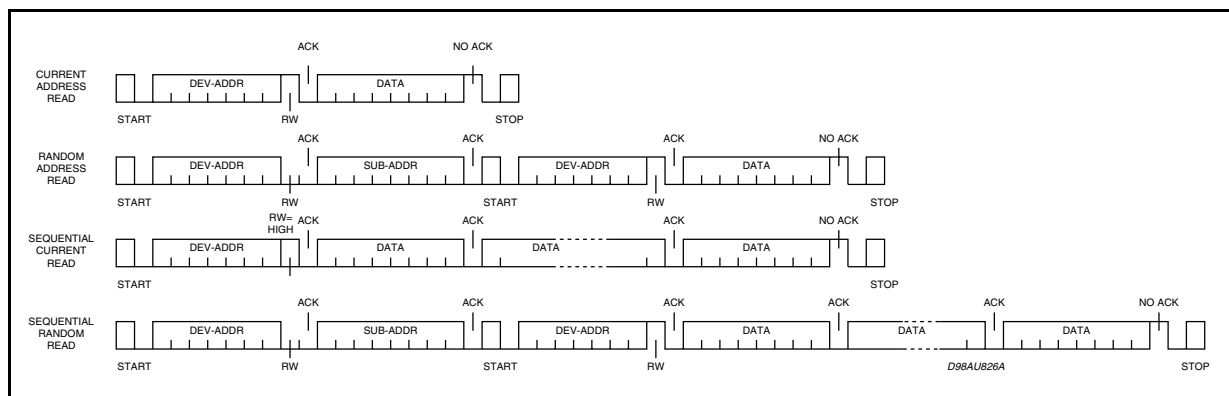

Figure 11. Read Mode Sequence



3.4 - READ OPERATION (see Fig. 11)

3.4.1 - Current byte address read

The STA013 has an internal byte address counter. Each time a byte is written or read, this counter is incremented.

For the current byte address read mode, following a START condition the master sends the device address with the RW bit set to 1.

The STA013 acknowledges this and outputs the byte addressed by the internal byte address counter. The master does not acknowledge the received byte, but terminates the transfer with a STOP condition.

3.4.2 - Sequential address read

This mode can be initiated with either a current address read or a random address read. However in this case the master does acknowledge the data byte output and the STA013 continues to output the next byte in sequence.

To terminate the streams of bytes the master does not acknowledge the last received byte, but

terminates the transfer with a STOP condition.

The output data stream is from consecutive byte addresses, with the internal byte address counter automatically incremented after one byte output.

4 - I²C REGISTERS

The following table gives a description of the MPEG Source Decoder (STA013) register list.

The first column (HEX_COD) is the hexadecimal code for the sub-address.

The second column (DEC_COD) is the decimal code.

The third column (DESCRIPTION) is the description of the information contained in the register.

The fourth column (RESET) indicate the reset value if any. When no reset value is specified, the default is "undefined".

The fifth column (R/W) is the flag to distinguish register "read only" and "read and write", and the useful size of the register itself.

Each register is 8 bit wide. The master shall operate reading or writing on 8 bits only.

I²C REGISTERS

HEX_COD	DEC_COD	DESCRIPTION	RESET	R/W
\$00	0	VERSION		R (8)
\$01	1	IDENT	0xAC	R (8)
\$05	5	PLLCTL [7:0]	0xA1	R/W (8)
\$06	6	PLLCTL [20:16] (MF[4:0]=M)	0x0C	R/W (8)
\$07	7	PLLCTL [15:12] (IDF[3:0]=N)	0x00	R/W (8)
\$0B	11	reserved		
\$0C	12	REQ_POL	0x01	R/W (8)
\$0D	13	SCLK_POL	0x04	R/W (8)
\$0F	15	ERROR_CODE	0x00	R (8)
\$10	16	SOFT_RESET	0x00	W (8)
\$13	19	PLAY	0x01	R/W(8)
\$14	20	MUTE	0x00	R/W(8)
\$16	22	CMD_INTERRUPT	0x00	R/W(8)
\$18	24	DATA_REQ_ENABLE	0x00	R/W(8)
\$40	64	SYNCSTATUS	0x00	R (8)
\$41	65	ANCCOUNT_L	0x00	R (8)
\$42	66	ANCCOUNT_H	0x00	R (8)

I²C REGISTERS (continued)

HEX_COD	DEC_COD	DESCRIPTION	RESET	R/W
\$43	67	HEAD_H[23:16]	0x00	R(8)
\$44	68	HEAD_M[15:8]	0x00	R(8)
\$45	69	HEAD_L[7:0]	0x00	R(8)
\$46	70	DLA	0x00	R/W (8)
\$47	71	DLB	0xFF	R/W (8)
\$48	72	DRA	0x00	R/W (8)
\$49	73	DRB	0xFF	R/W (8)
\$50	80	MFSDF_441	0x00	R/W (8)
\$51	81	PLLFRAC_441_L	0x00	R/W (8)
\$52	82	PLLFRAC_441_H	0x00	R/W (8)
\$54	84	PCM DIVIDER	0x03	R/W (8)
\$55	85	PCMCONF	0x21	R/W (8)
\$56	86	PCM CROSS	0x00	R/W (8)
\$59	89	ANC_DATA_1 [7:0]	0x00	R (8)
\$5A	90	ANC_DATA_2 [15:8]	0x00	R (8)
\$5B	91	ANC_DATA_3 [23:16]	0x00	R (8)
\$5C	92	ANC_DATA_4 [31:24]	0x00	R (8)
\$5D	93	ANC_DATA_5 [39:32]	0x00	R (8)
\$61	97	MFSDF (X)	0x07	R/W (8)
\$63	99	DAC_CLK_MODE	0x00	R/W (8)
\$64	100	PLLFRAC_L	0x46	R/W (8)
\$65	101	PLLFRAC_H	0x5B	R/W (8)
\$67	103	FRAME_CNT_L	0x00	R (8)
\$68	104	FRAME_CNT_M	0x00	R (8)
\$69	105	FRAME_CNT_H	0x00	R (8)
\$6A	106	AVERAGE_BITRATE	0x00	R (8)
\$71	113	SOFTVERSION		R (8)
\$72	114	RUN	0x00	R/W (8)
\$77	119	TREBLE_FREQUENCY_LOW	0x00	R/W (8)
\$78	120	TREBLE_FREQUENCY_HIGH	0x00	R/W (8)
\$79	121	BASS_FREQUENCY_LOW	0x00	R/W (8)
\$7A	122	BASS_FREQUENCY_HIGH	0x00	R/W (8)
\$7B	123	TREBLE_ENHANCE	0x00	R/W (8)
\$7C	124	BASS_ENHANCE	0x00	R/W (8)
\$7D	125	TONE_ATTEN	0x00	R/W (8)

Note:

- 1) The HEX_COD is the hexadecimal address that the microcontroller has to generate to access the information.
- 2) RESERVED: register used for production test only, or for future use.

4.1 - STA013 REGISTERS DESCRIPTION

The STA013 device includes 128 I²C registers. In this document, only the user-oriented registers are described. The undocumented registers are reserved. These registers must never be accessed (in Read or in Write mode). The Read-Only registers must never be written.

The following table describes the meaning of the abbreviations used in the I²C registers description:

Symbol	Comment
NA	Not Applicable
UND	Undefined
NC	No Charge
RO	Read Only
WO	Write Only
R/W	Read and Write
R/WS	Read, Write in specific mode

VERSION

Address: 0x00

Type: RO

MSB							LSB
b7	b6	b5	b4	b3	b2	b1	b0
V8	V7	V6	V5	V4	V3	V2	V1

The VERSION register is read-only and it is used to identify the IC on the application board.

IDENT

Address: 0x01

Type: RO

Software Reset: 0xAC

Hardware Reset: 0xAC

MSB							LSB
b7	b6	b5	b4	b3	b2	b1	b0
1	0	1	0	1	1	0	0

IDENT is a read-only register and is used to identify the IC on an application board. IDENT always has the value "0xAC"

PLLCTL

Address: 0x05

Type: R/W

Software Reset: 0x21

Hardware Reset: 0x21

MSB

LSB

b7	b6	b5	b4	b3	b2	b1	b0
XTO_BUF	XTOD_IS	OCLK_EN	SYS2O_CLK	PPLD_IS	XTI2DS_PCLK	XTI2O_CLK	UPD_FRAC

UPD_FRAC: when is set to 1, update FRAC in the switching circuit. It is set to 1 after autoboot.

XTI2OCLK: when is set to 1, use the XTI as input of the divider X instead of VCO output. It is set to 0 on HW reset.

XTI2DSPCLK: when is to 1, set use the XTI as input of the divider S instead of VCO output. It is set to 0 on HW reset.

PLLDIS: when set to 1, the VCO output is disabled. It is set to 0 on HW reset.

SYS2OCLK: when is set to 1, the OCLK frequency is equal to the system frequency. It is useful for testing. It is set to 0 on HW reset.

OCLKEN: when is set to 1, the OCLK pad is enable as output pad. It is set to 1 on HW reset.

XTODIS: when is set to 1, the XTO pad is disabled. It is set to 0 on HW reset.

XTO_BUF: when this bit is set, the pin nr. 28 (OUT_CLOCK/DATA_REQ) is enabled. It is set to 0 after autoboot.

PLLCTL (M)

Address: 0x06

Type: R/W

Software Reset: 0x0C

Hardware Reset: 0x0C

PLLCTL (N)

Address: 0x07

Type: R/W

Software Reset: 0x00

Hardware Reset: 0x00

The M and N registers are used to configure the STA013 PLL by DSP embedded software.

M and N registers are R/W type but they are completely controlled, on STA013, by DSP software.

REQ_POL

Address: 0x0C

Type: R/W

Software Reset: 0x01

Hardware Reset: 0x00

Hardware Reset: 0x01

The REQ_POL registers is used to program the polarity of the DATA_REQ line.

MSB							LSB
b7	b6	b5	b4	b3	b2	b1	b0
0	0	0	0	0	0	0	1

Default polarity (the source sends data when the DATA_REQ line is high)

MSB							LSB
b7	b6	b5	b4	b3	b2	b1	b0
0	0	0	0	0	1	0	1

Inverted polarity (the source sends data when the DATA_REQ line is low)

SCKL_POL

Address: 0x0D

Type: R/W

Software Reset: 0x04

Hardware Reset: 0x04

MSB							LSB
b7	b6	b5	b4	b3	b2	b1	b0
X	X	X	X	X	0	0	0
					1	0	0

(1)
(2)

X = don't care

SCKL_POL is used to select the working polarity of the Input Serial Clock (SCKR).

- (1) If SCKL_POL is set to 0x00, the data (SDI) are sent with the falling edge of SCKR and sampled on the rising edge.
- (2) If SCKL_POL is set to 0x04, the data (SDI) are sent with the rising edge of SCKR and sampled on the falling edge.

ERROR_CODE

Address: 0x0F

Type: RO

Software Reset: 0x00

Hardware Reset: 0x00

MSB							LSB
b7	b6	b5	b4	b3	b2	b1	b0
X	X	X	X	0	0	0	0
				0	0	0	1
				0	0	1	0

(1)
(2)
(3)

X = don't care

ERROR_CODE register contains the last error occurred if any. The codes can be as follows:

Code		Description
(1)	0x00	No error since the last SW or HW Reset
(2)	0x01	CRC Failure
(3)	0x02	DATA not available

SOFT_RESET

Address: 0x10

Type: WO

Software Reset: 0x00

Hardware Reset: 0x00

MSB							LSB
b7	b6	b5	b4	b3	b2	b1	b0
X	X	X	X	X	X	X	0
							1

X = don't care; 0 = normal operation; 1 = reset

When this register is written, a soft reset occurs. The STA013 core command register and the interrupt register are cleared. The decoder goes in to idle mode.

PLAY

Address: 0x13

Type: R/W

Software Reset: 0x01

Hardware Reset: 0x01

MSB							LSB
b7	b6	b5	b4	b3	b2	b1	b0
X	X	X	X	X	X	X	0
							1

X = don't care; 0 = normal operation; 1 = play

The PLAY command is handled according to the state of the decoder, as described in section 2.5. PLAY only becomes active when the decoder is in DECODE mode.



MUTE

Address: 0x14

Type: R/W

Software Reset: 0x00

Hardware Reset: 0x00

MSB							LSB
b7	b6	b5	b4	b3	b2	b1	b0
X	X	X	X	X	X	X	0
							1

X = don't care; 0 = normal operation; 1 = mute

The MUTE command is handled according to the state of the decoder, as described in section 2.5.

MUTE sets the clock running.

CMD_INTERRUPT

Address: 0x16

Type: R/W

Software Reset: 0x00

Hardware Reset: 0x00

MSB							LSB
b7	b6	b5	b4	b3	b2	b1	b0
X	X	X	X	X	X	X	0
							1

X = don't care;
0 = normal operation;
1 = write into I²C/Ancillary Data

The INTERRUPT is used to give STA013 the command to write into the I2C/Ancillary Data Buffer (Registers: 0x59 ... 0x5D). Every time the Master has to extract the new buffer content (5 bytes) it writes into this register, setting it to a non-zero value.

DATA_REQ_ENABLE

Address: 0x18

Type: R/W

Software Reset: 0x00

Hardware Reset: 0x00

MSB						LSB		Description
b7	b6	b5	b4	b3	b2	b1	b0	
X	X	X	X	X	0	X	X	buffered output clock
X	X	X	X	X	1	X	X	request signal

The DATA_REQ_ENABLE register is used to configure Pin n. 28 working as buffered output clock or data request signal, used for multimedia

mode.

The buffered Output Clock has the same frequency than the input clock (XTI)

SYNCSTATUS

Address: 0x40

Type: RO

Software Reset: 0x00

Hardware Reset: 0x00

MSB						LSB		Description
b7	b6	b5	b4	b3	b2	b1	b0	
X	X	X	X	X	X	SS1	SS0	
						0	0	Research of sync word
						0	1	Wait for Confirmation
						1	0	Synchronised
						1	1	not used

ANCCOUNT_L

Address: 0x41

Type: RO

Software Reset: 0x00

Hardware Reset: 0x00

MSB							LSB
b7	b6	b5	b4	b3	b2	b1	b0
AC7	AC6	AC5	AC4	AC3	AC2	AC1	AC0

ANCCOUNT_H

Address: 0x42

Type: RO

Software Reset: 0x00

Hardware Reset: 0x00

ANCCOUNT_H

MSB							LSB
b7	b6	b5	b4	b3	b2	b1	b0
AC15	AC14	AC13	AC12	AC11	AC10	AC9	AC8

ANCCOUNT registers are logically concatenated and indicate the number of Ancillary Data bits available at every correctly decoded MPEG frame.

HEAD_H[23:16]

MSB							LSB
b7	b6	b5	b4	b3	b2	b1	b0
X	X	X	H20	H19	H18	H17	H16

x = don't care

HEAD_M[15:8]

MSB							LSB
b7	b6	b5	b4	b3	b2	b1	b0
H15	H14	H13	H12	H11	H10	H9	H8

HEAD_L[7:0]

MSB							LSB
b7	b6	b5	b4	b3	b2	b1	b0
H7	H6	H5	H4	H3	H2	H1	H0

Address: 0x43, 0x44, 0x45

Type: RO

Software Reset: 0x00

Hardware Reset: 0x00

Head[1:0] emphasis

Head[2] original/copy

Head[3] copyrightHead

[5:4] mode extension

Head[7:6] mode

Head[8] private bit

Head[9] padding bit

Head[11:10] sampling frequency index

Head[15:12] bitrate index

Head[16] protection bit

Head[18:17] layer

Head[19] ID

Head[20] ID_ex

The HEAD registers can be viewed as logically concatenated to store the MPEG Layer III Header content. The set of three registers is updated every time the synchronisation to the new MPEG frame is achieved

The meaning of the flags are shown in the following tables:

MPEG IDs

IDex	ID	
0	0	MPEG 2.5
0	1	reserved
1	0	MPEG 2
1	1	MPEG 1

Layer

in Layer III these two flags must be set always to "01".

Protection_bit

It equals "1" if no redundancy has been added and "0" if redundancy has been added.

Bitrate_index

indicates the bitrate (Kbit/sec) depending on the MPEG ID.

bitrate index	ID = 1	ID = 0
'0000'	free	free
'0001'	32	8
'0010'	40	16
'0011'	48	24
'0100'	56	32
'0101'	64	40
'0110'	80	48
'0111'	96	56
'1000'	112	64
'1001'	128	80
'1010'	160	96
'1011'	192	112
'1100'	224	128
'1101'	256	144
'1110'	320	160
'1111'	forbidden	forbidden

Sampling Frequency

indicates the sampling frequency of the encoded audio signal (KHz) depending on the MPEG ID

Sampling Frequency	MPEG1	MPEG2	MPEG2.5
'00'	44.1	22.05	11.03
'01'	48	24	12
'10'	32	16	8
'11'	reserved	reserved	reserved

Padding bit

if this bit equals '1', the frame contains an additional slot to adjust the mean bitrate to the sampling frequency, otherwise this bit is set to '0'.

Private bit

Bit for private use. This bit will not be used in the future by ISO/IEC.

Mode

Indicates the mode according to the following table. The joint stereo mode is intensity_stereo and/or ms_stereo.

mode	mode specified
'00'	stereo
'01'	joint stereo (intensity_stereo and/or ms_stereo)
'10'	dual_channel
'11'	single_channel (mono)

Mode extension

These bits are used in joint stereo mode. They indicate which type of joint stereo coding method is applied. The frequency ranges, over which the intensity_stereo and ms_stereo modes are applied, are implicit in the algorithm.

Copyright

If this bit is equal to '0', there is no copyright on the bitstream, '1' means copyright protected.

Original/Copy

This bit equals '0' if the bitstream is a copy, '1' if it is original.

Emphasis

Indicates the type of de-emphasis that shall be used.

emphasis	emphasis specified
'00'	none
'01'	50/15 microseconds
'10'	reserved
'11'	CCITT J,17

DLA

Address: 0x46

Type: R/W

Software Reset: 0x00

Hardware Reset: 0x00

MSB				LSB				Description
b7	b6	b5	b4	b3	b2	b1	b0	
DLA7	DLA6	DLA5	DLA4	DLA3	DLA2	DLA1	DLA0	OUTPUT ATTENUATION
0	0	0	0	0	0	0	0	NO ATTENUATION
0	0	0	0	0	0	0	1	-1dB
0	0	0	0	0	0	1	0	-2dB
:	:	:	:	:	:	:	:	:
0	1	1	0	0	0	0	0	-96dB

DLA register is used to attenuate the level of audio output at the Left Channel using the butterfly shown in Fig. 12. When the register is set to

255 (0xFF), the maximum attenuation is achieved. A decimal unit correspond to an attenuation step of 1 dB.

Figure 12. Volume Control and Output Setup

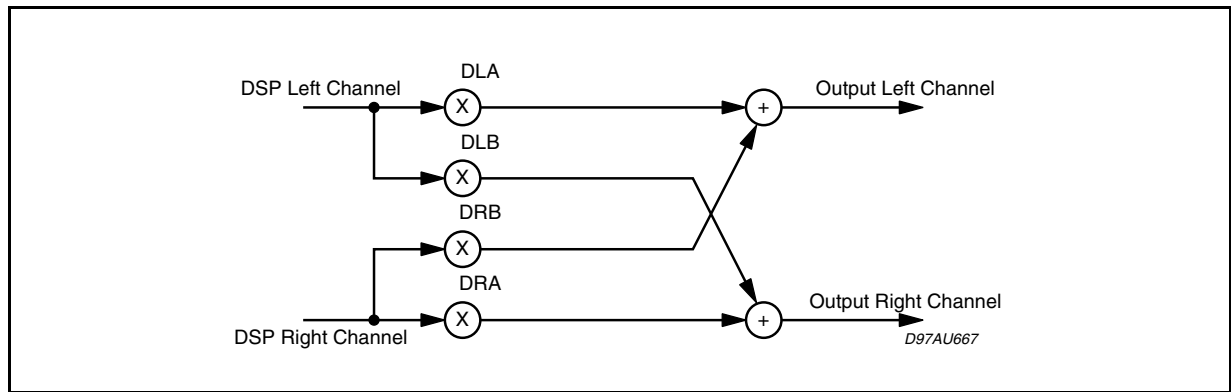

DLB

Address: 0x47

Type: R/W

Software Reset: 0xFF

Hardware Reset: 0xFF

MSB				LSB				Description
b7	b6	b5	b4	b3	b2	b1	b0	
DLB7	DLB6	DLB5	DLB4	DLB3	DLB2	DLB1	DLB0	OUTPUT ATTENUATION
0	0	0	0	0	0	0	0	NO ATTENUATION
0	0	0	0	0	0	0	1	-1dB
0	0	0	0	0	0	1	0	-2dB
:	:	:	:	:	:	:	:	:
0	1	1	0	0	0	0	0	-96dB

DLB register is used to re-redirect the Left Channel on the Right, or to mix both the Channels.

Default value is 0x00, corresponding at the maximum attenuation in the re-direction channel.

DRA

Address: 0x48

Type: R/W

Software Reset: 0X00

Hardware Reset: 0X00

MSB				LSB				
b7	b6	b5	b4	b3	b2	b1	b0	Description
DRA7	DRA6	DRA5	DRA4	DRA3	DRA2	DRA1	DRA0	OUTPUT ATTENUATION
0	0	0	0	0	0	0	0	NO ATTENUATION
0	0	0	0	0	0	0	1	-1dB
0	0	0	0	0	0	1	0	-2dB
:	:	:	:	:	:	:	:	:
0	1	1	0	0	0	0	0	-96dB

DRA register is used to attenuate the level of audio output at the Right Channel using the butterfly shown in Fig. 11. When the register is set to

255 (0xFF), the maximum attenuation is achieved. A decimal unit correspond to an attenuation step of 1 dB.

DRB

Address: 0x49

Type: R/W

Software Reset: 0xFF

Hardware Reset: 0xFF

MSB				LSB				
b7	b6	b5	b4	b3	b2	b1	b0	Description
DRB7	DRB6	DRB5	DRB4	DRB3	DRB2	DRB1	DRB0	OUTPUT ATTENUATION
0	0	0	0	0	0	0	0	NO ATTENUATION
0	0	0	0	0	0	0	1	-1dB
0	0	0	0	0	0	1	0	-2dB
:	:	:	:	:	:	:	:	:
0	1	1	0	0	0	0	0	-96dB

DRB register is used to re-direct the Right Channel on the Left, or to mix both the Channels.

Default value is 0x00, corresponding at the maximum attenuation in the re-direction channel.

MFSDF_441

Address: 0x50

Type: R/W

Software Reset: 0x00

Hardware Reset: 0x00

MSB						LSB	
b7	b6	b5	b4	b3	b2	b1	b0
X	X	X	M4	M3	M2	M1	M0

This register contains the value for the PLL X driver for the 44.1KHz reference frequency.

The VCO output frequency, when decoding 44.1KHz bitstream, is divided by (MFSDF_441 +1)

PLLFRAC_441_L

Address: 0x51

Type: R/W

Software Reset: 0x00

Hardware Reset: 0x00

MSB						LSB	
b7	b6	b5	b4	b3	b2	b1	b0
PF7	PF6	PF5	PF4	PF3	PF2	PF1	PF0



PLLFRAC_441_H

Address: 0x52

Type: R/W

Software Reset: 0x00

Hardware Reset: 0x00

MSB							LSB
b7	b6	b5	b4	b3	b2	b1	b0
PF15	PF14	PF13	PF12	PF11	PF10	PF9	PF8

The registers are considered logically concatenated and contain the fractional values for the PLL, for 44.1KHz reference frequency.

(see also PLLFRAC_L and PLLFRAC_H registers)

PCMDIVIDER

Address: 0x54

Type: RW

Software Reset: 0x03

Hardware Reset: 0x03

7	6	5	4	3	2	1	0
PD7	PD6	PD5	PD4	PD3	PD2	PD1	PD0

PCMDIVIDER is used to set the frequency ratio between the OCLK (Oversampling Clock for DACs), and the SCKT (Serial Audio Transmitter Clock).

The relation is the following:

$$SCKT_freq = \frac{OCLK_freq}{2(1 + PCM_DIV)}$$

The Oversampling Factor (O_FAC) is related to OCLK and SCKT by the following expression:

- 1) $OCLK_freq = O_FAC * LRCKT_Freq$
(DAC relation)
- 2) $OCLK_Freq = 2 * (1+PCM_DIV) * 32 * LRCKT_Freq$ (when 16 bit PCM mode is used)
- 3) $OCLK_Freq = 2 * (1+PCM_DIV) * 64 * LRCKT_Freq$ (when 32 bit PCM mode is used)
- 4) $PCM_DIV = (O_FAC/64) - 1$ in 16 bit mode
- 5) $PCM_DIV = (O_FAC/128) - 1$ in 32 bit mode

Example for setting:

MSB							LSB			
b7	b6	b5	b4	b3	b2	b1	b0	Description		
PD7	PD6	PD5	PD4	PD3	PD2	PD1	PD0			
0	0	0	0	0	1	1	1	16 bit mode	512 x Fs	
0	0	0	0	0	1	0	1	16 bit mode	384 x Fs	
0	0	0	0	0	0	1	1	16 bit mode	256 x Fs	
0	0	0	0	0	0	1	1	32 bit mode	512 x Fs	
0	0	0	0	0	0	1	0	32 bit mode	384 x Fs	
0	0	0	0	0	0	0	1	32 bit mode	256 x Fs	

for 16 bit PCM Mode

- O_FAC = 512 ; PCM_DIV = 7
- O_FAC = 256 ; PCM_DIV = 3
- O_FAC = 384 ; PCM_DIV = 5

for 32 bit PCM Mode

- O_FAC = 512 ; PCM_DIV = 3
- O_FAC = 256 ; PCM_DIV = 1
- O_FAC = 384 ; PCM_DIV = 2

PCMCONF

Address: 0x55

Type: R/W

Software Reset: 0x21

Hardware Reset: 0x21

MSB				LSB				Description
b7	b6	b5	b4	b3	b2	b1	b0	
X	ORD	DIF	INV	FOR	SCL	PREC (1)	PREC (1)	
X	1							PCM order the LS bit is transmitted First
X	0							PCM order the MS bit is transmitted First
X		0						The word is right padded
X		1						The word is left padded
X			1					LRCKT Polarity compliant to I2S format
X			0					LRCKT Polarity inverted
X				0				I2S format
X				1				Different formats
X					1			Data are sent on the rising edge of SCKT
X					0			Data are sent on the falling edge of SCKT
X						0	0	16 bit mode (16 slots transmitted)
X						0	1	18 bit mode (18 slots transmitted)
X						1	0	20 bit mode (20 slots transmitted)
X						1	1	24 bit mode (24 slots transmitted)

PCMCONF is used to set the PCM Output Interface configuration:

ORD: PCM order. If this bit is set to '1', the LS Bit is transmitted first, otherwise MS Bit is transmitted first.

DIF: PCM_DIFF. It is used to select the position of the valid data into the transmitted word. This setting is significant only in 18/20/24 bit/word mode. If it is set to '0' the word is right-padded, otherwise it is left-padded.

INV (fig.13): It is used to select the LRCKT clock polarity. If it is set to '1' the polarity is compliant to I2S format (low -> left , high -> right), otherwise the LRCKT is inverted. The default value is '0'. (if I2S have to be selected, must be set to '1' in the STA013 configuration phase).

Figure 13. LRCKT Polarity Selection

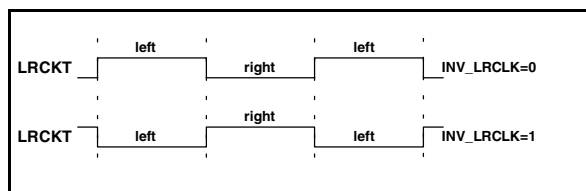

FOR: FORMAT is used to select the PCM Output Interface format.

After hw and sw reset the value is set to 0 corresponding to I²S format.

SCL (fig.14): used to select the Transmitter Serial Clock polarity. If set to '1' the data are sent on the

rising edge of SCKT and sampled on the falling. If set to '0', the data are sent on the falling edge and sampled on the rising. This last option is the most commonly used by the commercial DACs. The default configuration for this flag is '0'.

Figure 14. SCKT Polarity Selection

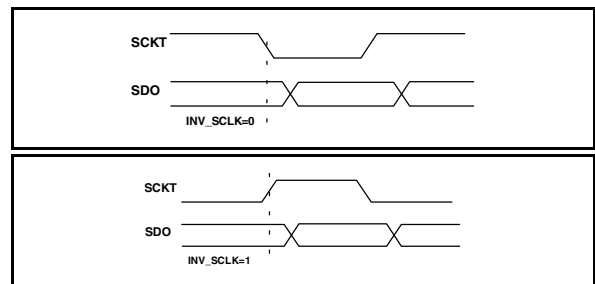

PREC [1:0]: PCM PRECISION

It is used to select the PCM samples precision, as follows:

'00': 16 bit mode (16 slots transmitted)

'01': 18 bit mode (32 slots transmitted)

'10': 20 bit mode (32 slots transmitted)

'11': 24 bit mode (32 slots transmitted)

The PCM samples precision in STA013 can be 16 or 18-20-24 bits.

When STA013 operates in 16 (18-20-24) bits mode, the number of bits transmitted during a LRCKT period is 32 (64).

PCMCROSS

Address: 0x56

Type: R/W

Software Reset: 0x00

Hardware Reset: 0x00

MSB							LSB		Description
b7	b6	b5	b4	b3	b2	b1	b0		
X	X	X	X	X	X	0	0	Left channel is mapped on the left output. Right channel is mapped on the Right output	
X	X	X	X	X	X	0	1	Left channel is duplicated on both Output channels.	
X	X	X	X	X	X	1	0	Right channel is duplicated on both Output channels	
X	X	X	X	X	X	1	1	Right and Left channels are toggled	

The default configuration for this register is '0x00'.

ANCILLARY DATA BUFFER

Address: 0x59 - 0x5D

Type: RO

Software Reset: 0x00

Hardware Reset: 0x00

STA013 can extract max 56 bytes/MPEG frame. To know the number of A.D. bits available every MPEG frame, the ANCCOUNT_L and ANCCOUNT_H registers (0x41 and 0x42) have to be read.

The buffer dimension is 5 bytes, written by STA013 core in sequential order. The timing information to read the buffer can be obtained by reading the FRAME_CNT registers (0x67 - 0x69).

To fill up the buffer with a new 5-bytes slot, the STA013 waits until a CMD_INTERRUPT register is written by the master.

MFSDF (X)

Address: 0x61

Type: R/W

Software Reset: 0x07

Hardware Reset: 0x07

MSB							LSB
b7	b6	b5	b4	b3	b2	b1	b0
X	X	X	M4	M3	M2	M1	M0

The register contains the values for PLL X divider (see Fig. 7).

The value is changed by the internal STA013 Core, to set the clocks frequencies, according to the incoming bitstream. This value can be even set by the user to select the PCM interface configuration.

The VCO output frequency is divided by (X+1).

This register is a reference for 32KHz and 48 KHz input bitstream.

DAC_CLK_MODE

Address: 0x63

Type: RW

Software Reset: 0x00

Hardware Reset: 0x00

MSB							LSB
b7	b6	b5	b4	b3	b2	b1	b0
X	X	X	X	X	X	X	MODE

This register is used to select the operating mode for OCLK clock signal.

If it is set to '1', the OCLK frequency is fixed, and it is maintained to the value fixed by the user even if the sampling frequency of the incoming bit-stream changes.

If the MODE flag is set to '0', the OCLK frequency changes, and can be set to $(512, 384, 256) * F_s$. The default configuration for this mode is $256 * F_s$.

When this mode is selected, the default OCLK frequency is 12.288 MHz.

PLLFRAC_L ([7:0])

MSB							LSB
b7	b6	b5	b4	b3	b2	b1	b0
PF7	PF6	PF5	PF4	PF3	PF2	PF1	PF0

PLLFRAC_H ([15:8])

MSB							LSB
b7	b6	b5	b4	b3	b2	b1	b0
PF15	PF14	PF13	PF12	PF11	PF10	PF9	PF8

Address: 0x64 - 0x65

Type: R/W

Software Reset: 0x46 | 0x5B

Hardware Reset: 0xNA | 0x5B

The registers are considered logically concatenated and contain the fractional values for the PLL, used to select the internal configuration.

After Reset, the values are NA, and the operational setting are done when the MPEG synchronisation is achieved.

The following formula describes the relationships among all the STA013 fractional PLL parameters:

$$OCLK_Freq = \left[\frac{1}{X+1} \right] \cdot \left[\frac{MCLK_freq}{N+1} \right] \cdot \left[M+1 + \frac{FRAC}{65536} \right]$$

where:

FRAC=256 x FRAC_H + FRAC_L (decimal)

These registers are a reference for 48 / 24 / 12 / 32 / 16 / 8KHz audio.

FRAME_CNT_L

MSB							LSB
b7	b6	b5	b4	b3	b2	b1	b0
FC7	FC6	FC5	FC4	FC3	FC2	FC1	FC0

FRAME_CNT_M

MSB							LSB
b7	b6	b5	b4	b3	b2	b1	b0
FC15	FC14	FC13	FC12	FC11	FC10	FC9	FC8

FRAME_CNT_H

MSB							LSB
b7	b6	b5	b4	b3	b2	b1	b0
FC23	FC22	FC21	FC20	FC19	FC18	FC17	FC16

Address: 0x67, 0x68, 0x69

Type: RO

Software Reset: 0x00

Hardware Reset: 0x00

The three registers are considered logically concatenated and compose the Global Frame Counter as described in the table.

It is updated at every decoded MPEG Frame. The registers are reset on both hardware and software reset.

AVERAGE_BITRATE

Address: 0x6A

Type: RO

Software Reset: 0x00

Hardware Reset: 0x00

MSB							LSB
b7	b6	b5	b4	b3	b2	b1	b0
AB7	AB6	AB5	AB4	AB3	AB2	AB1	AB0

AVERAGE_BITRATE is a read-only register and it contains the average bitrate of the incoming bit-stream. The value is rounded with an accuracy of 1 Kbit/sec.

SOFTVERSION

Address: 0x71

Type: RO

MSB							LSB
b7	b6	b5	b4	b3	b2	b1	b0
SV7	SV6	SV5	SV4	SV3	SV2	SV1	SV0

After the STA013 boot, this register contains the version code of the embedded software.

RUN

Address: 0x72

Type: RW

Software Reset: 0x00

Hardware Reset: 0x00

MSB							LSB
b7	b6	b5	b4	b3	b2	b1	b0
X	X	X	X	X	X	X	RUN

Setting this register to 1, STA013 leaves the idle state, starting the decoding process. The Microcontroller is allowed to set the RUN flag, once all the control registers have been initialized.

TREBLE_FREQUENCY_LOW

Address: 0x77

Type: RW

Software Reset: 0x00

Hardware Reset: 0x00

MSB							LSB
b7	b6	b5	b4	b3	b2	b1	b0
TF7	TF6	TF5	TF4	TF3	TF2	TF1	TF0

TREBLE_FREQUENCY_HIGH

Address: 0x78

Type: RW

Software Reset: 0x00

Hardware Reset: 0x00

MSB							LSB
b7	b6	b5	b4	b3	b2	b1	b0
TF15	TF14	TF13	TF12	TF11	TF10	TF9	TF8

The registers TREBLE_FREQUENCY-HIGH and TREBLE_FREQUENCY-LOW, logically concatenated as a 16 bit wide register, are used to select the frequency, in Hz, where the selected frequency is +12dB respect to the stop band.

By setting these registers, the following rule must be kept:

$Treble_Freq < Fs/2$

BASS_FREQUENCY_LOW

Address: 0x79

Software Reset: 0x00

Hardware Reset: 0x00

MSB							LSB
b7	b6	b5	b4	b3	b2	b1	b0
BF7	BF6	BF5	BF4	BF3	BF2	BF1	BF0

BASS_FREQUENCY_HIGH

Address: 0x7A

Software Reset: 0x00

Hardware Reset: 0x00

MSB							LSB
b7	b6	b5	b4	b3	b2	b1	b0
BF15	BF14	BF13	BF12	BF11	BF10	BF9	BF8

The registers BASS_FREQUENCY_HIGH and BASS_FREQUENCY_LOW, logically concatenated as a 16 bit wide register, are used to select the frequency, in Hz, where the selected frequency is -12dB respect to the pass-band. By setting the BASS_FREQUENCY registers, the following rules must be kept:

$Bass_Freq \leq Treble_Freq$

$Bass_Freq > 0$

(suggested range: 20 Hz < Bass_Freq < 750 Hz)

Example:

Bass = 200Hz

Treble = 3kHz

TFS

15	14	13	12	11	10	9	8	7	6	5	4	3	2	1	0
0	0	0	0	1	0	1	1	1	0	1	1	1	0	0	0

BFS

15	14	13	12	11	10	9	8	7	6	5	4	3	2	1	0
0	0	0	0	0	0	0	0	1	1	0	0	1	0	0	0



TREBLE_ENHANCE

Address: 0x7B

Software Reset: 0x00

Hardware Reset: 0x00

Signed number (2 complement)

This register is used to select the enhancement or attenuation STA013 has to perform on Treble Frequency range at the digital signal.

A decrement (increment) of a decimal unit corresponds to a step of attenuation (enhancement) of 1.5dB.

The allowed Attenuation/Enhancement range is [-18dB, +18dB].

MSB							LSB
b7	b6	b5	b4	b3	b2	b1	b0
TE7	TE6	TE5	TE4	TE3	TE2	TE1	TE0

MSB								LSB	ENHANCE/ATTENUATION
b7	b6	b5	b4	b3	b2	b1	b0	1.5dB step	
0	0	0	0	1	1	0	0	+18	
0	0	0	0	1	0	1	1	+16.5	
0	0	0	0	1	0	1	0	+15	
0	0	0	0	1	0	0	1	+13.5	
⋮									
0	0	0	0	0	0	0	1	+1	
0	0	0	0	0	0	0	0	0	
1	1	1	1	1	1	1	1	-1	
⋮									
1	1	1	1	0	1	1	1	-13.5	
1	1	1	1	0	1	1	0	-15	
1	1	1	1	0	1	0	0	-16.5	
1	1	1	1	0	1	0	0	-18	

STA013 - STA013B - STA013T

BASS_ENHANCE

Address: 0x7C

Software Reset: 0x00

Hardware Reset: 0x00

MSB				LSB			
b7	b6	b5	b4	b3	b2	b1	b0
BE7	BE6	BE5	BE4	BE3	BE2	BE1	BE0

Signed number (2 complement)

This register is used to select the enhancement or attenuation STA013 has to perform on Bass Frequency range at the digital signal.

A decrement (increment) of a decimal unit corresponds to a step of attenuation (enhancement) of 1.5dB.

The allowed Attenuation/Enhancement range is [-18dB, +18dB].

MSB				LSB				ENHANCE/ATTENUATION
b7	b6	b5	b4	b3	b2	b1	b0	1.5dB step
0	0	0	0	1	1	0	0	+18
0	0	0	0	1	0	1	1	+16.5
0	0	0	0	1	0	1	0	+15
0	0	0	0	1	0	0	1	+13.5
⋮								
0	0	0	0	0	0	0	1	+1
0	0	0	0	0	0	0	0	0
1	1	1	1	1	1	1	1	-1
⋮								
1	1	1	1	0	1	1	1	-13.5
1	1	1	1	0	1	1	0	-15
1	1	1	1	0	1	0	0	-16.5
1	1	1	1	0	1	0	0	-18

TONE_ATTEN

Address: 0x7D

Type: RW

Software Reset: 0x00

Hardware Reset: 0x00

MSB				LSB			
b7	b6	b5	b4	b3	b2	b1	b0
TA7	TA6	TA5	TA4	TA3	TA2	TA1	TA0

In the digital output audio, the full signal is achieved with 0 dB of attenuation. For this reason, before applying Bass & Treble Control, the user has to set the TONE_ATTEN register to the maximum value of enhancement is going to perform.

For example, in case of a 0 dB signal (max. level) only attenuation would be possible. If enhancement is desired, the signal has to be attenuated accordingly before in order to reserve a margin in dB. An increment of a decimal unit corresponds to a Tone Attenuation step of 1.5dB.

MSB				LSB				ATTENUATION
b7	b6	b5	b4	b3	b2	b1	b0	-1.5dB step
0	0	0	0	0	0	0	0	0dB
0	0	0	0	0	0	0	1	-1.5dB
0	0	0	0	1	0	1	0	-3dB
0	0	0	0	0	0	1	1	-4.5dB
⋮								
0	0	0	0	1	0	1	0	-15dB
0	0	0	0	1	0	1	1	-16.5dB
0	0	0	0	1	1	0	0	-18dB

5. GENERAL INFORMATION

5.1. MPEG 2.5 Layer III Algorithm.

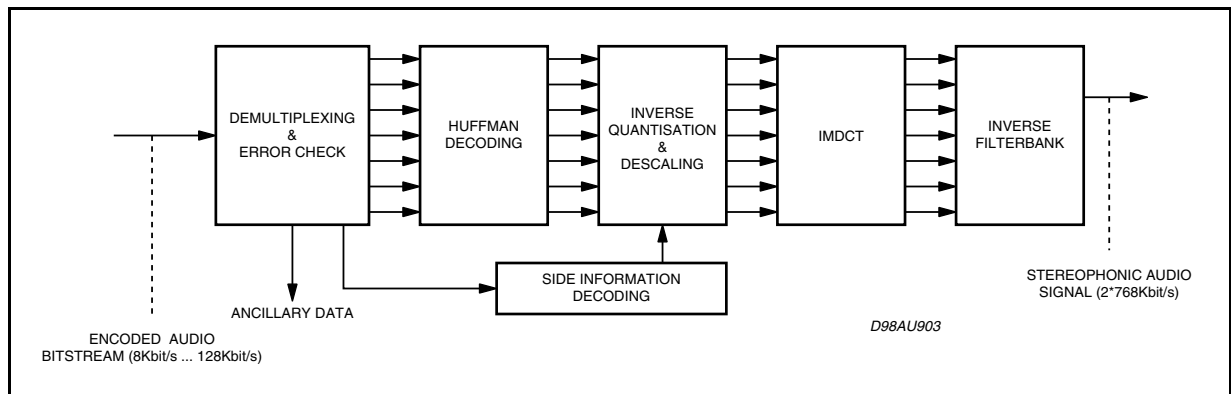

5.2 - MPEG Ancillary Data Description:

As specified in the ISO standard, the MPEG Layer III frames have a variable bit length, and are constant in time depending on the audio sam-

pling frequencies. The time duration of the Layer III frames is shown in Tab 2.

Table2: MPEG Layer III Frames Time Duration

Sampling Frequency (KHz)	48	44.1	32	24	22.5	16	12	11.025	8
MPEG Frame Length (ms)	24	29	36	24	29	36	48	48	72

STA013 - STA013B - STA013T

The Ancillary Data extraction on STA013 can be described as follow:

STA013 has a specific Ancillary Data buffer, mapped into the I2C registers:

0x59	ANC_DATA_1
0x5A	ANC_DATA_2
0x5B	ANC_DATA_3
0x5C	ANC_DATA_4
0x5D	ANC_DATA_5

Since the content of Ancillary Data into an MPEG Frame STA013 can extract is max. 56 bytes, a

specific register, to require the new 5 byte slot to STA003 is needed.

This register is:

0x16	CMD_INTERRUPT
------	---------------

The interrupt register, is sensitive to any non-zero value written by the Microcontroller. When this register is updated the Ancillary Data buffer is filled up with new values and the registers

0x41	ANCCOUNT_L
0x42	ANCCOUNT_H

are updated (decremented) accordingly.

5.3. I/O CELL DESCRIPTION

1) CMOS Tristate Output Pad Buffer, 4mA, with Slew Rate Control / Pin numbers 9, 10, 11, 20, 28

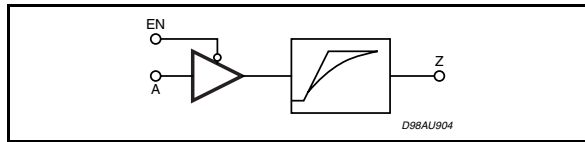

OUTPUT PIN	MAX LOAD
Z	100pF

2) CMOS Bidir Pad Buffer, 4mA, with Slew Rate Control / Pin numbers 3, 12

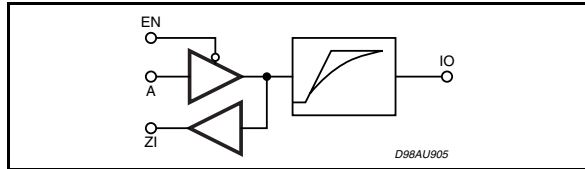

OUTPUT PIN	CAPACITANCE	OUTPUT PIN	MAX LOAD
IO	5pF	IO	100pF

3) CMOS Input Pad Buffer / Pin numbers 4, 5, 6, 8, 21, 25

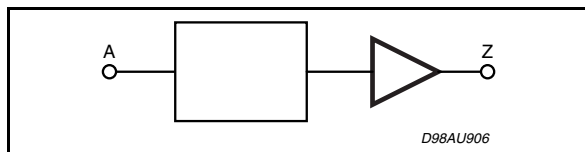

INPUT PIN	CAPACITANCE
A	3.5pF

4) CMOS Input Pad Buffer with Active Pull-Up / Pin numbers 7, 24, 26

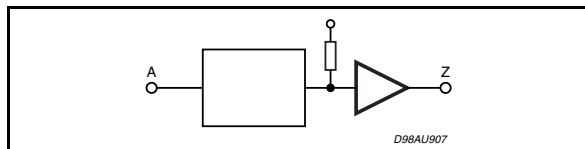

INPUT PIN	CAPACITANCE
A	3.5pF

5.4. TIMING DIAGRAMS

5.4.1. Audio DAC Interface

a) OCLK in output. The audio PLL is used to clock the DAC

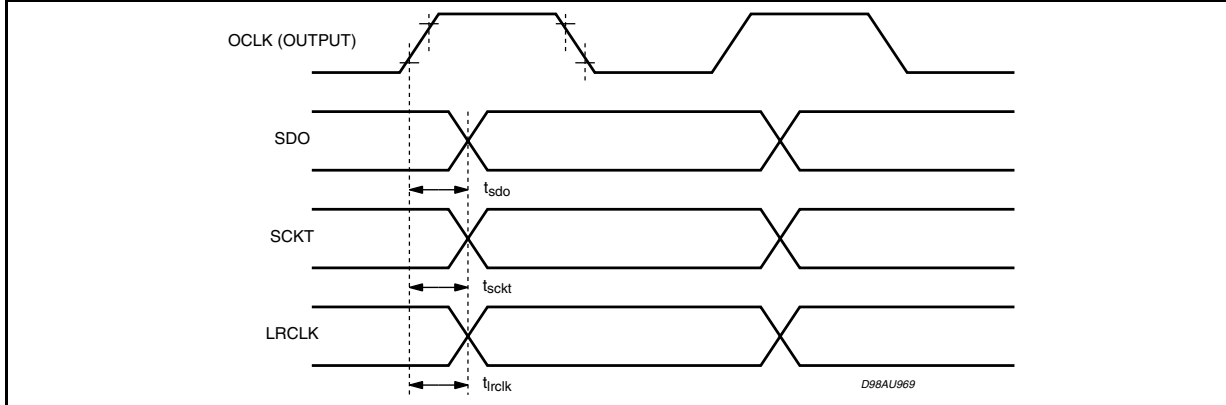

$$t_{sdo} = 3.5 + \text{pad_timing}(\text{Cload_SDO}) - \text{pad_timing}(\text{Cload_OCLK})$$

$$t_{sckt} = 4 + \text{pad_timing}(\text{Cload_SCKT}) - \text{pad_timing}(\text{Cload_OCLK})$$

$$t_{lrckt} = 3.5 + \text{pad_timing}(\text{Cload_LRCCKT}) - \text{pad_timing}(\text{Cload_OCLK})$$

Pad-timing versus load

Load (pF)	Pad_timing
25	2.90ns
50	3.82ns
75	4.68ns
100	5.52ns

Clload_XXX is the load in pF on the XXX output. pad_timing (Clload_XXX) is the propagation delay added to the XXX pad due to the load.

b) OCLK in input.

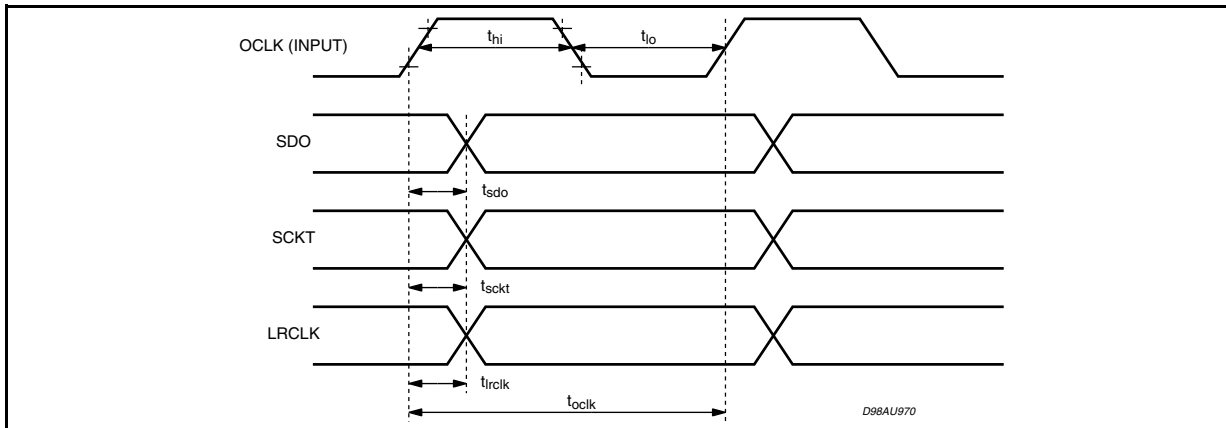

$$T_{hi} \text{ min} = 3\text{ns}$$

$$T_{lo} \text{ min} = 3\text{ns}$$

$$T_{ockl} \text{ min} = 25\text{ns}$$

$$t_{sdo} = 5.5 + \text{pad_timing}(\text{Cload_SDO}) \text{ ns}$$

$$t_{sckt} = 6 + \text{pad_timing}(\text{Cload_SCKT}) \text{ ns}$$

$$t_{lrckt} = 5.5 + \text{pad_timing}(\text{Cload_LRCKT}) \text{ ns}$$

5.4.2. Bitstream input interface (SDI, SCKR, BIT_EN) SCL_POL = 0

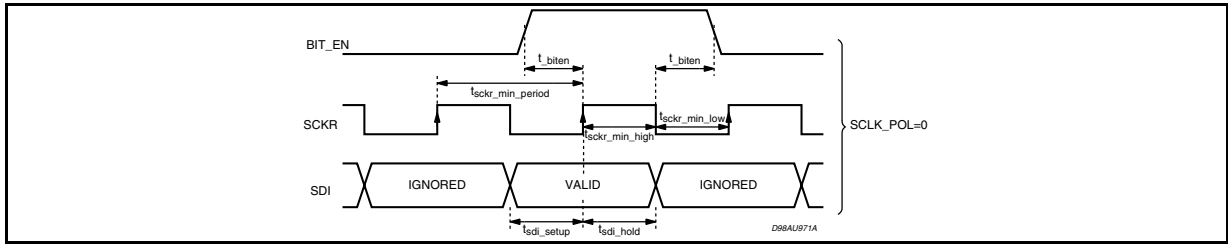

5.4.2. Bitstream input interface (SDI, SCKR, BIT_EN) SCL_POL = 1

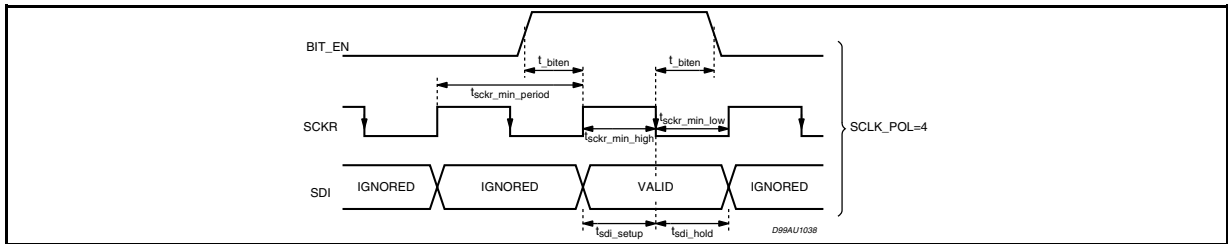

$t_{sdi_setup_min} = 2ns$

$t_{sdi_hold_min} = 3ns$

$t_{sckr_min_hi} = 10ns$

$t_{sckr_min_low} = 10ns$

$t_{sckr_min_lperiod} = 50ns$

$t_{biten} (min) = 2ns$

5.4.3. SRC_INT

This is an asynchronous input used in "broadcast" mode.

SRC_INT is active low

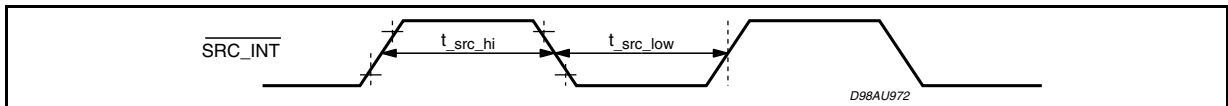

t_{src_low} min duration is 50ns (1DSP clock period)

t_{src_high} min duration is 50ns (1DSP clock period)

5.4.4. XTI,XTO and CLK_OUT timings

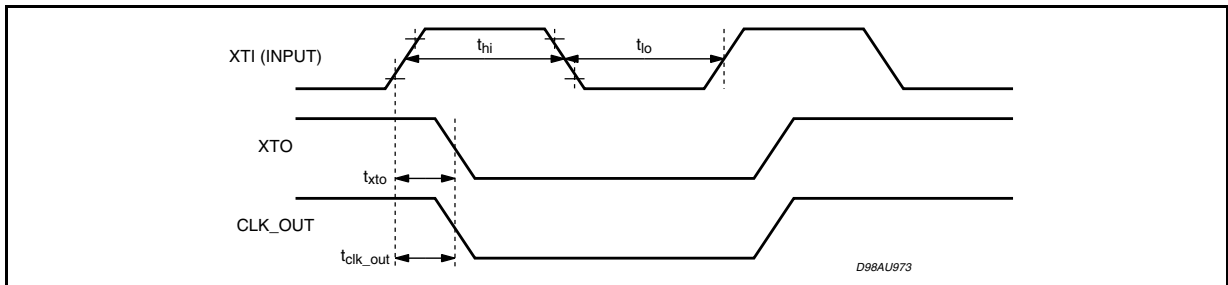

$t_{xto} = 1.40 + pad_timing (Cload_XTO) ns$

$t_{clk_out} = 4 + pad_timing (Cload_CLK_OUT) ns$

Note: In "multimedia" mode, the CLK_OUT pad is DATA_REQ. In that case, no timing is given between the XTI input and this pad.

5.4.5. **RESET**

The Reset min duration ($t_{reset_low_min}$) is 100ns

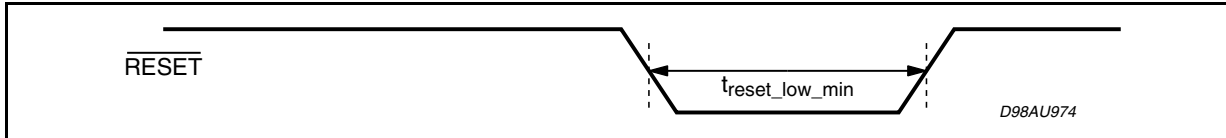

5.5. **CONFIGURATION FLOW**

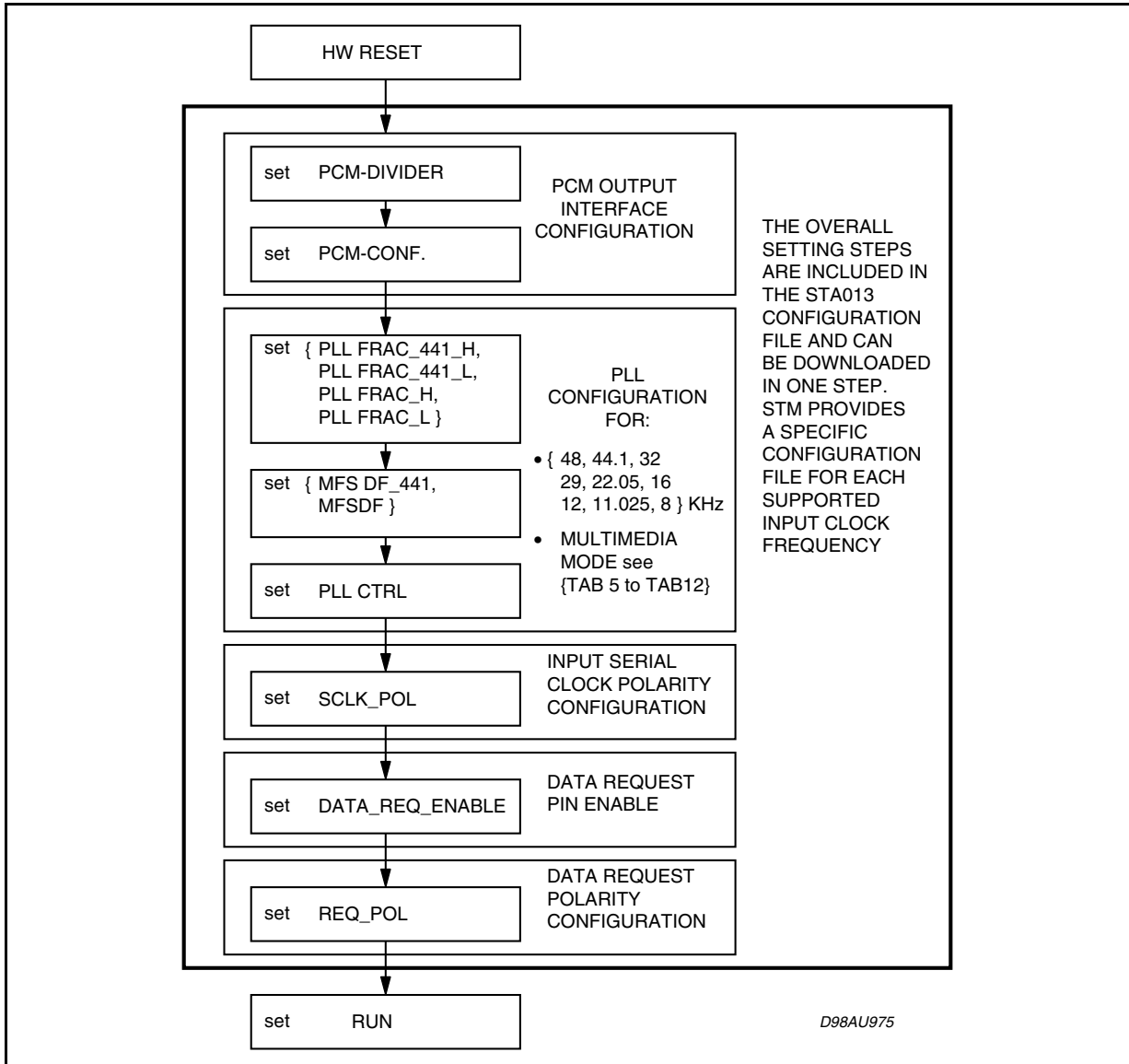

Table 5:
 PLL Configuration Sequence For
 10MHz Input Clock
 256 Oversapling Clock

REGISTER ADDRESS	NAME	VALUE
6	reserved	18
11	reserved	3
97	MFSDF (x)	15
80	MFSDF-441	16
101	PLLFRAC-H	169
82	PLLFRAC-441-H	49
100	PLLFRAC-L	42
81	PLLFRAC-441-L	60
5	PLLCTRL	161

Table 7:
 PLL Configuration Sequence For
 14.31818MHz Input Clock
 256 Oversapling Rathio

REGISTER ADDRESS	NAME	VALUE
6	reserved	12
11	reserved	3
97	MFSDF (x)	15
80	MFSDF-441	16
101	PLLFRAC-H	187
82	PLLFRAC-441-H	103
100	PLLFRAC-L	58
81	PLLFRAC-441-L	119
5	PLLCTRL	161

Table 6:
 PLL Configuration Sequence For
 10MHz Input Clock
 384 Oversapling Rathio

REGISTER ADDRESS	NAME	VALUE
6	reserved	17
11	reserved	3
97	MFSDF (x)	9
80	MFSDF-441	10
101	PLLFRAC-H	110
82	PLLFRAC-441-H	160
100	PLLFRAC-L	152
81	PLLFRAC-441-L	186
5	PLLCTRL	161

Table 8:
 PLL Configuration Sequence For
 14.31818MHz Input Clock
 384 Oversapling Rathio

REGISTER ADDRESS	NAME	VALUE
6	reserved	11
11	reserved	3
97	MFSDF (x)	6
80	MFSDF-441	7
101	PLLFRAC-H	3
82	PLLFRAC-441-H	157
100	PLLFRAC-L	211
81	PLLFRAC-441-L	157
5	PLLCTRL	161

Table 9:
PLL Configuration Sequence For
14.31818MHz Input Clock
512 Oversampling Rathio

REGISTER ADDRESS	NAME	VALUE
6	reserved	11
11	reserved	3
97	MFSDf (x)	6
80	MFSDf-441	7
101	PLLFRAC-H	3
82	PLLFRAC-441-H	157
100	PLLFRAC-L	211
81	PLLFRAC-441-L	157
5	PLLCTRL	161

Table 11:
PLL Configuration Sequence For
14.7456MHz Input Clock
384 Oversampling Rathio

REGISTER ADDRESS	NAME	VALUE
6	reserved	10
11	reserved	3
97	MFSDf (x)	8
80	MFSDf-441	9
101	PLLFRAC-H	64
82	PLLFRAC-441-H	124
100	PLLFRAC-L	0
81	PLLFRAC-441-L	0
5	PLLCTRL	161

Table 10:
PLL Configuration Sequence For
14.7456MHz Input Clock
256 Oversampling Rathio

REGISTER ADDRESS	NAME	VALUE
6	reserved	12
11	reserved	3
97	MFSDf (x)	15
80	MFSDf-441	16
101	PLLFRAC-H	85
82	PLLFRAC-441-H	4
100	PLLFRAC-L	85
81	PLLFRAC-441-L	0
5	PLLCTRL	161

Table 12:
PLL Configuration Sequence For
14.7456MHz Input Clock
512 Oversampling Rathio

REGISTER ADDRESS	NAME	VALUE
6	reserved	9
11	reserved	2
97	MFSDf (x)	5
80	MFSDf-441	6
101	PLLFRAC-H	0
82	PLLFRAC-441-H	184
100	PLLFRAC-L	0
81	PLLFRAC-441-L	0
5	PLLCTRL	161

5.6. STA013 CONFIGURATION FILE FORMAT

The STA013 Configuration File is an ASCII format. An example of the file format is the following:

58 1
42 4
128 15
.....

It is a sequence of rows and each one can be interpreted as an I²C command.
The first part of the row is the I²C address (register) and the second one is the I²C data (value).
To download the STA013 configuration file into the device, a sequence of write operation to STA013 I²C interface must be performed.
The following program describes the I²C routine to be implemented for the configuration driver:

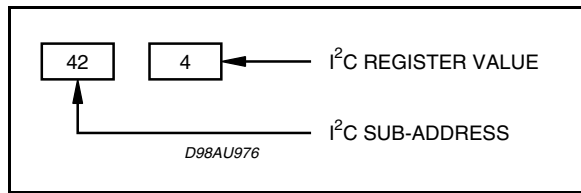

STA013 Configuration Code (pseudo code)

download cfg - file

```
{  
  fopen (cfg_file);  
  fp:=1;          /*set file pointer to first row */  
  
  do {  
    I2C_start_cond;          /* generate I2C start condition for STA013 device address */  
    I2C_write_dev_addr;      /* write STA013 device address */  
    I2C_write_subaddress (fp); /* write subaddress */  
    I2C_write_data (fp);     /* write data */  
    I2C_stop_cond;          /* generate I2C stop condition */  
    fp++;                /* update pointer to new file row */  
  }  
  while (!EDF)          /* repeat until End of File */  
}
```

Note:1

STA013 is a device based on an integrated DSP core. Some of the I²C registers default values are loaded after an internal DSP boot operation. The bootstrap time is 60 micro second. Only after this time length, the data in the register can be considered stable.

Note 2:

Refer also to the application note 1090

DIM.	mm			inch		
	MIN.	TYP.	MAX.	MIN.	TYP.	MAX.
A			2.65			0.104
a1	0.1		0.3	0.004		0.012
b	0.35		0.49	0.014		0.019
b1	0.23		0.32	0.009		0.013
C		0.5			0.020	
c1	45° (typ.)					
D	17.7		18.1	0.697		0.713
E	10		10.65	0.394		0.419
e		1.27			0.050	
e3		16.51			0.65	
F	7.4		7.6	0.291		0.299
L	0.4		1.27	0.016		0.050
S	8° (max.)					

OUTLINE AND MECHANICAL DATA

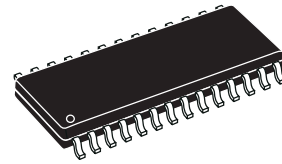

SO28

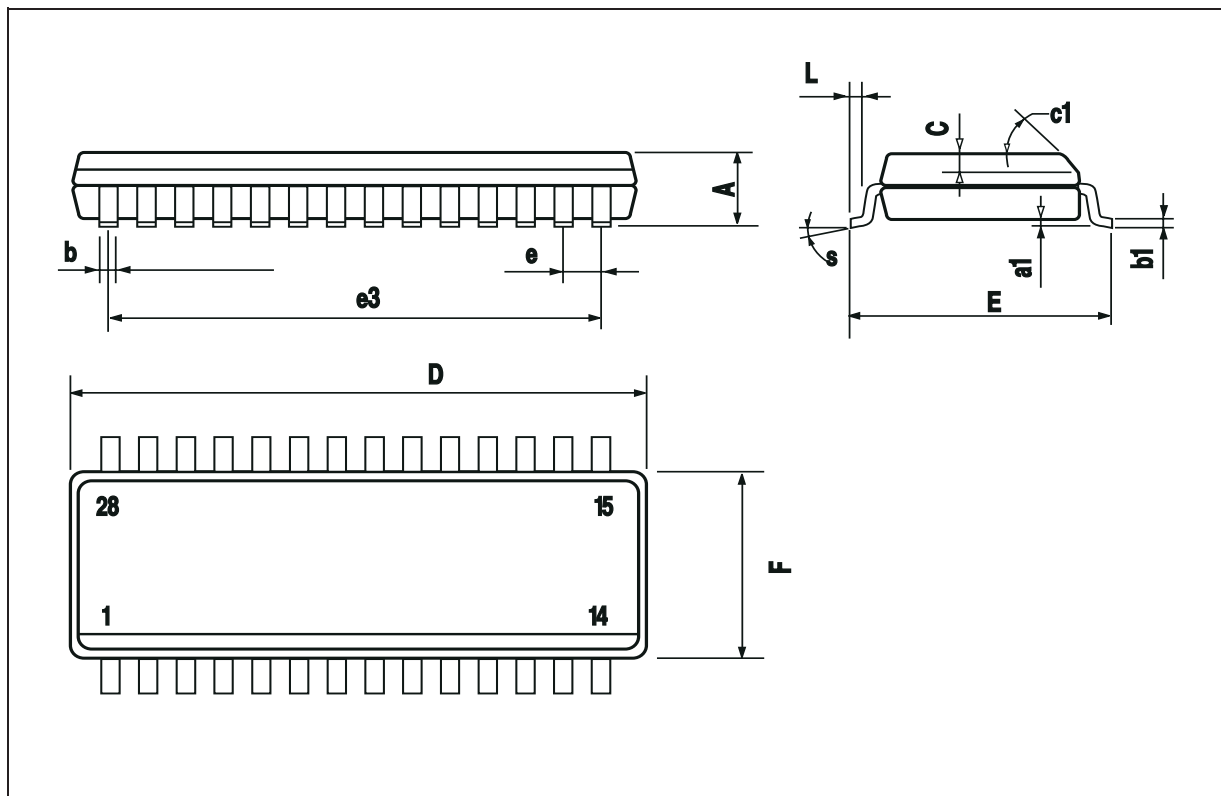

STA013 - STA013B - STA013T

DIM.	mm			inch		
	MIN.	TYP.	MAX.	MIN.	TYP.	MAX.
A			1.60			0.063
A1	0.05		0.15	0.002		0.006
A2	1.35	1.40	1.45	0.053	0.055	0.057
B	0.30	0.37	0.45	0.012	0.015	0.018
C	0.09		0.20	0.004		0.008
D	11.80	12.00	12.20	0.464	0.472	0.480
D1	9.80	10.00	10.20	0.386	0.394	0.401
D3		8.00			0.315	
E	11.80	12.00	12.20	0.464	0.472	0.480
E1	9.80	10.00	10.20	0.386	0.394	0.401
E3		8.00			0.315	
e		0.80			0.031	
L	0.45	0.60	0.75	0.018	0.024	0.030
L1		1.00			0.039	
k	0° (min.), 3.5° (typ.), 7° (max.)					

OUTLINE AND MECHANICAL DATA

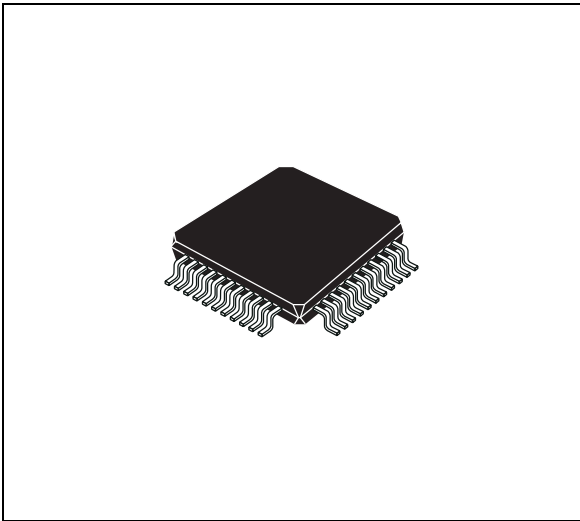

TQFP44 (10 x 10 x 1.4mm)

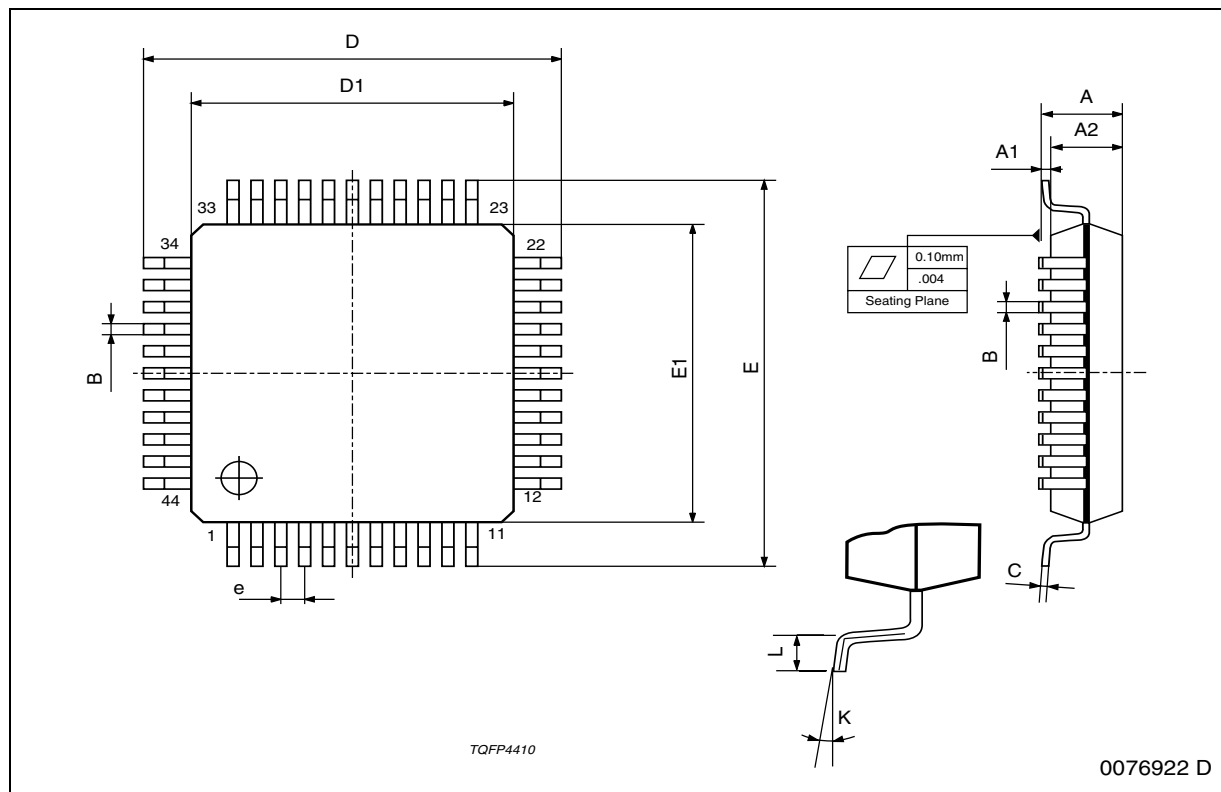

DIM.	mm			inch		
	MIN.	TYP.	MAX.	MIN.	TYP.	MAX.
A			1.700			0.067
A1	0.350	0.400	0.450	0.014	0.016	0.018
A2		1.100			0.043	
b		0.500			0.20	
D		8.000			0.315	
D1		5.600			0.220	
e		0.800			0.031	
E		8.000			0.315	
E1		5.600			0.220	
f		1.200			0.047	

OUTLINE AND MECHANICAL DATA

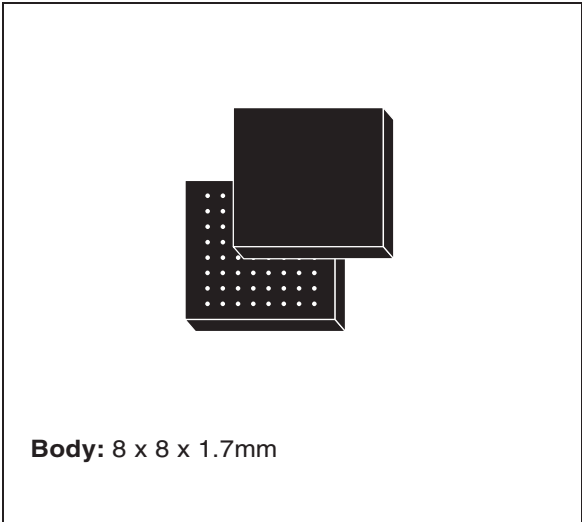

LFBGA64

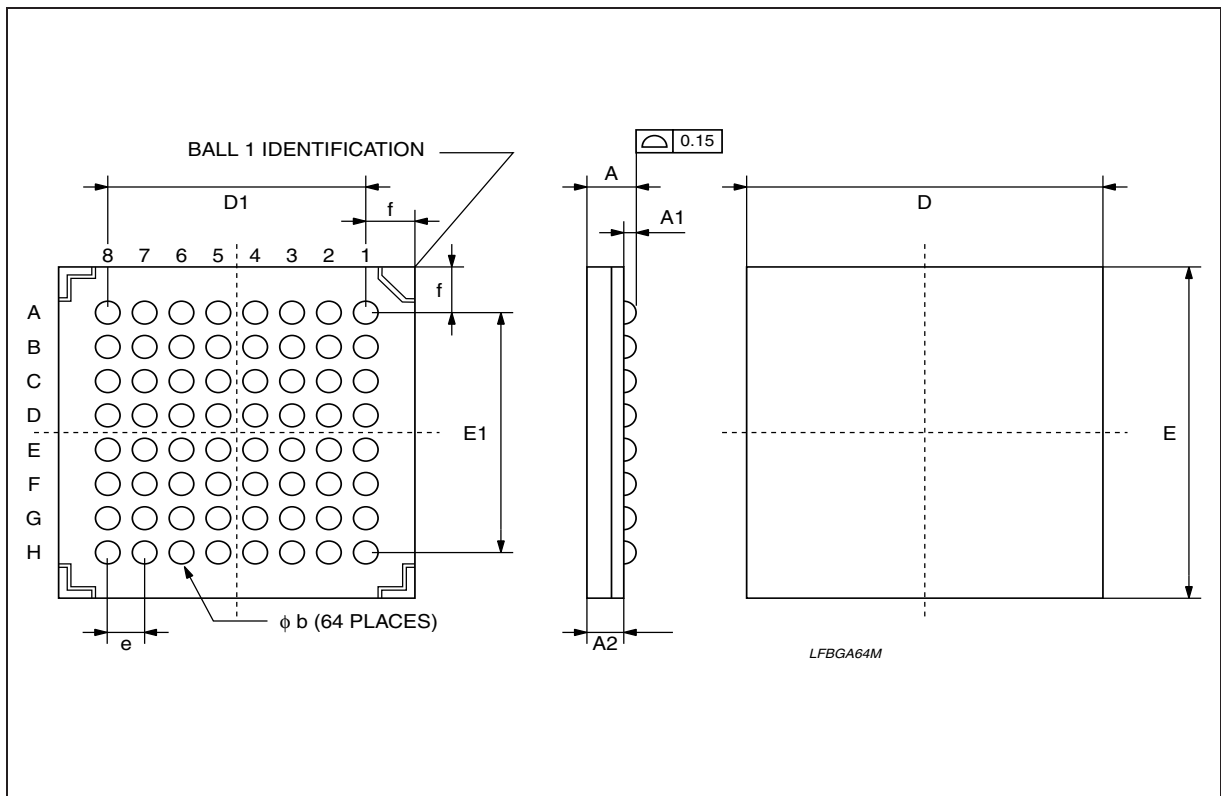

Information furnished is believed to be accurate and reliable. However, STMicroelectronics assumes no responsibility for the consequences of use of such information nor for any infringement of patents or other rights of third parties which may result from its use. No license is granted by implication or otherwise under any patent or patent rights of STMicroelectronics. Specifications mentioned in this publication are subject to change without notice. This publication supersedes and replaces all information previously supplied. STMicroelectronics products are not authorized for use as critical components in life support devices or systems without express written approval of STMicroelectronics.

The ST logo is a registered trademark of STMicroelectronics.
All other names are the property of their respective owners

© 2004 STMicroelectronics - All rights reserved

STMicroelectronics GROUP OF COMPANIES

Australia – Belgium - Brazil - Canada - China – Czech Republic - Finland - France - Germany - Hong Kong - India - Israel - Italy - Japan -
Malaysia - Malta - Morocco - Singapore - Spain - Sweden - Switzerland - United Kingdom - United States

www.st.com