

# The Ethernet

A Local Area Network

Data Link Layer  
and  
Physical Layer  
Specifications



Digital Equipment Corporation  
Maynard, MA



Intel Corporation  
Santa Clara, CA

XEROX

Xerox Corporation  
Stamford, CT

Version 1.0

September 30, 1980

### IMPORTANT INFORMATION AND DISCLAIMERS

1. This specification includes subject matter relating to a patent(s) of Xerox Corporation. No license under such patent(s) is granted by implication, estoppel or otherwise as a result of publication of this specification. Applicable licenses may be obtained from Xerox Corporation.
2. This specification is furnished for informational purposes only. Digital, Xerox, and Intel do not warrant or represent that this specification or any products made in conformance with it will work in the intended manner, nor do they assume responsibility for any errors that it may contain or have any liabilities or obligations for damages, including but not limited to special, indirect or consequential damages arising out of or in connection with the use of this specification in any way. This specification shall not necessarily apply to any product that may be developed by Digital, Xerox, or Intel. Any such products that may be developed shall be sold under the then current terms and conditions of sale.



## Preface

This document contains the specification of the Ethernet, a local area network developed jointly by Digital Equipment Corporation, Intel Corporation, and Xerox Corporation. The Ethernet specification arises from an extensive collaborative effort of the three corporations, and several years of work at Xerox on an earlier prototype Ethernet.

This specification is intended as a design reference document, rather than an introduction or tutorial. Readers seeking introductory material are directed to the reference list in Section 2, which cites several papers describing the intent, theory, and history of the Ethernet.

This document contains 7 sections, falling into three main groups:

Sections 1, 2, and 3 provide an overall description of the Ethernet, including its goals, and the scope of the specification.

Sections 4 and 5 describe the architectural structure of the Ethernet in terms of a functional model consisting of two layers, the Data Link Layer and the Physical Layer.

Sections 6 and 7 specify the two layers in detail, providing the primary technical specification of the Ethernet.

Readers wishing to obtain an initial grasp of the organization and content of the specification will be best served by reading Sections 1, 3, and 4. Readers involved in actual implementation of the Ethernet will find Sections 5, 6, and 7 to contain the central material of the specification. Section 2 provides references, and the appendices provide supplementary material.

The approach taken in the specification of the Data Link Layer in Section 6 is a procedural one; in addition to describing the necessary algorithms in English and control flow charts, the specification presents these algorithms in the language Pascal. This approach makes clear the required behavior of Data Link Layer, while leaving individual implementations free to exploit any appropriate technology.

Because the procedural approach is not suitable for specifying the details of the Physical Layer, Section 7 uses carefully worded English prose and numerous figures and tables to specify the necessary parameters of this layer.

Some aspects of the Ethernet are necessarily discussed in more than one place in this specification. Whenever any doubt arises concerning the official definition in such a case, the reader should utilize the Pascal procedural specification of the Data Link Layer in Section 6.5, and the detailed prose specification of the Physical Layer in Sections 7.2 through 7.9.

One aspect of an overall network architecture which is not addressed by this specification is network management. The network management facility performs operation, maintenance, and planning functions for the network:

- Operation functions include parameter setting, such as address selection.
- Maintenance functions provide for fault detection, isolation, and repair.
- Planning functions include collection of statistical and usage information, necessary for planned network growth.

While network management itself is properly performed outside the Ethernet Data Link and Physical Layers, it requires appropriate additional interfaces to those layers, which will be defined in a subsequent version of this specification.

**Table of Contents**

Preface	i
1. INTRODUCTION	1
2. REFERENCES	3
3. GOALS AND NON-GOALS	4
3.1 Goals	4
3.2 Non-Goals	5
4. FUNCTIONAL MODEL OF THE ETHERNET ARCHITECTURE	6
4.1 Layering	8
4.2 Data Link Layer	9
4.3 Physical Layer	10
4.4 Ethernet Operation and the Functional Model	12
4.4.1 Transmission Without Contention	12
4.4.2 Reception Without Contention	12
4.4.3 Collisions: Handling of Contention	13
5. INTER-LAYER INTERFACES	15
5.1 Client Layer to Data Link Layer	15
5.2 Data Link Layer to Physical Layer	16
6. ETHERNET DATA LINK LAYER SPECIFICATION	19
6.1 Data link Layer Overview and Model	19
6.2 Frame format	19
6.2.1 Address Fields	21
6.2.1.1 Destination Address Field	21
6.2.1.2 Source Address Field	21
6.2.2 Type Field	21
6.2.3 Data Field	22
6.2.4 Frame Check Sequence Field	22
6.2.5 Frame Size Limitations	22
6.3 Frame Transmission	23
6.3.1 Transmit Data Encapsulation	23
6.3.1.1 Frame Assembly	23
6.3.1.2 Frame Check Sequence Generation	23
6.3.2 Transmit Link Management	23

6.3.2.1 Carrier Deference	23
6.3.2.2 Interframe Spacing	24
6.3.2.3 Collision Handling	24
6.3.2.3.1 Collision Detection and Enforcement	24
6.3.2.3.2 Collision Backoff and Retransmission	25
6.4 Frame Reception	25
6.4.1 Receive Data Decapsulation	25
6.4.1.1 Framing	25
6.4.1.1.1 Maximum Frame Size	26
6.4.1.1.2 Integral Number of Octets in Frame	26
6.4.1.2 Address Recognition	26
6.4.1.2.1 Physical Addresses	26
6.4.1.2.2 Multicast Addresses	26
6.4.1.3 Frame Check Sequence Validation	26
6.4.1.4 Frame Disassembly	27
6.4.2 Receive Link Management	27
6.4.2.1 Collision Filtering	27
6.5 The Data Link Layer Procedural Model	27
6.5.1 Overview of the Procedural Model	27
6.5.1.1 Ground Rules for the Procedural Model	27
6.5.1.2 Use of Pascal in the Procedural Model	29
6.5.2 The Procedural Model	31
6.5.2.1 Global Declarations	34
6.5.2.1.1 Common Constants and Types	34
6.5.2.1.2 Transmit State Variables	35
6.5.2.1.3 Receive State Variables	35
6.5.2.1.4 Summary of Interlayer Interfaces	36
6.5.2.1.5 State Variable Initialization	37
6.5.2.2 Frame Transmission	38
6.5.2.3 Frame Reception	42
6.5.2.4 Common Procedures	44
7. ETHERNET PHYSICAL LAYER SPECIFICATION	45
7.1 Physical Channel Overview and Model	45
7.1.1 Channel Goals and Non-Goals	45
7.1.1.1 Goals	45
7.1.1.2 Non-Goals	45
7.1.2 Characteristics of the Channel	46
7.1.3 Functions Provided by the Channel	46
7.1.4 Implementation of the Channel	46
7.1.4.1 General Overview of Channel Hardware	47
7.1.4.2 Compatibility Interfaces	48
7.1.5 Channel Configuration Model	49
7.1.6 Channel Interfaces	53

7.2 Transceiver Cable Compatibility Interface Specifications	53
7.2.1 Transceiver Cable Signals	53
7.2.1.1 Transmit Signal	53
7.2.1.2 Receive Signal	54
7.2.1.3 Collision Presence Signal	54
7.2.1.4 Power	54
7.2.2 Transceiver Cable Parameters	54
7.2.2.1 Mechanical Configuration	54
7.2.2.2 Characteristic Impedance	55
7.2.2.3 Attenuation	55
7.2.2.4 Velocity of Propagation	55
7.2.2.5 Pulse Distortion	55
7.2.2.6 Resistance	55
7.2.2.7 Transfer Impedance	55
7.2.3 Transceiver Cable Connectors	56
7.2.4 Transceiver Cable Drive	56
7.2.5 Transceiver Cable Receive	57
7.2.5.1 Load Impedance and Termination	57
7.2.5.2 Common Mode and CMRR	57
7.3 Coaxial Cable Compatibility Interface Specifications	58
7.3.1 Coaxial Cable Component Specifications	58
7.3.1.1 Coaxial Cable Parameters	58
7.3.1.1.1 Characteristic Impedance	58
7.3.1.1.2 Attenuation	58
7.3.1.1.3 Velocity of Propagation	58
7.3.1.1.4 Mechanical Requirements	59
7.3.1.1.5 Pulse Distortion	59
7.3.1.1.6 Jacket Marking	59
7.3.1.1.7 Transfer Impedance	59
7.3.1.2 Coaxial Cable Connectors	60
7.3.1.3 Coaxial Cable Terminators	60
7.3.1.4 Transceiver-to-Coaxial Cable Connections	61
7.3.2 Coaxial Cable Signaling	61
7.4 Transceiver Specifications	62
7.4.1 Transceiver-to-Coaxial Cable Interface	62
7.4.1.1 Input Impedance	62
7.4.1.2 Bias Current	62
7.4.1.3 Transmit Output Levels	63
7.4.2 Transceiver-to-Transceiver Cable Interface	63
7.4.2.1 Transmit Pair	63
7.4.2.2 Receive Pair	63
7.4.2.3 Collision Presence Pair	64
7.4.2.4 Power Pair	64
7.4.3 Electrical Isolation	64



7.4.4 Reliability	64
7.5 Channel Logic	64
7.5.1 Channel Encoding	64
7.5.1.1 Encoder	65
7.5.1.2 Decoder	65
7.5.1.3 Preamble Generation	66
7.5.2 Collision Detect Signal	67
7.5.3 Carrier Sense Signal	67
7.5.4 Channel Framing	68
7.5.4.1 Beginning-of-Frame Sequence	68
7.5.4.2 End-of-Frame Sequence	69
7.6 Channel Configuration Requirements	69
7.6.1 Cable Sectioning	69
7.6.2 Transceiver Placement	70
7.6.3 System Grounding	70
7.6.4 Repeaters	71
7.6.4.1 Carrier Detect and Transmit Repeat	71
7.6.4.2 Collision Detect and Collision Repeat	71
7.6.4.3 Repeater Signal Generation	71
7.6.4.3.1 Signal Amplification	71
7.6.4.3.2 Signal Timing	71
7.7 Environment Specifications	72
7.7.1 Electromagnetic Environment	72
7.7.2 Temperature and Humidity	72

## Appendices

APPENDIX A: GLOSSARY	73
APPENDIX B: ASSIGNMENT OF ADDRESS AND TYPE VALUES	76
APPENDIX C: CRC IMPLEMENTATION	77
APPENDIX D: IMPLEMENTATION OF TRANSCEIVER CABLE DRIVER AND RECEIVER	80
APPENDIX E: INTERFRAME RECOVERY	82

## Figures and Tables

Figure 4-1: Ethernet Architecture and Typical Implementation	7
Figure 4-2: Architectural Layering	8
Figure 4-3: Data Link Layer Functions	10
Figure 4-4: Physical Layer Functions	11
Figure 6-1: Data Link Layer Frame Format	20
Figure 6-2: Structure of the Data Link Procedural Model	31
Figure 6-3: Control Flow Summary -- Client Layer Processes	32
Figure 6-4: Control Flow Summary -- Data Link Layer Processes	33
Figure 7-1: Physical Channel Configurations	50
Table 7-1: Physical Channel Propagation Delay Budget	52
Figure 7-2: Maximum Transceiver Cable Transfer Impedance	55
Figure 7-3: Typical Transceiver Cable Waveform	57
Figure 7-4: Maximum Coaxial Cable Transfer Impedance	60
Figure 7-5: Typical Coaxial Cable Waveform	62
Figure 7-6: Manchester Encoding	65
Figure 7-7: Preamble Encoding	66
Figure 7-8: Functional Logic of <code>collisionDetect</code> Signal	67
Figure 7-9: Functional Logic of <code>carrierSense</code> Signal	68
Figure C-1: CRC Implementation	78
Figure D-1: Typical Transceiver Cable Driver	80
Figure D-2: Typical Transceiver Cable Receiver	81



## 1. INTRODUCTION

The Ethernet local area network provides a communication facility for high speed data exchange among computers and other digital devices located within a moderate-sized geographic area. Its primary characteristics include:

### **Physical Layer:**

**Data rate:** 10 Million bits/sec

**Maximum station separation:** 2.5 Kilometers

**Maximum number of stations:** 1024

**Medium:** Shielded coaxial cable, base-band signalling

**Topology:** Branching non-rooted tree

### **Data Link Layer:**

**Link control procedure:** Fully distributed peer protocol, with statistical contention resolution (CSMA/CD)

**Message protocol:** Variable size frames, "best-effort" delivery

The Ethernet, like other local area networks, falls in a middle ground between long distance, low speed networks which carry data for hundreds or thousands of kilometers, and specialized, very high speed interconnections which are generally limited to tens of meters. The Ethernet is intended primarily for use in such areas as office automation, distributed data processing, terminal access, and other situations requiring economical connection to a local communication medium carrying bursty traffic at high peak data rates. Use in situations demanding resistance to hostile environments, real-time response guarantees, and so on, while not specifically excluded, do not constitute the primary environment for which the Ethernet is designed.

The precursor to the Ethernet specified in this document was the "Experimental Ethernet", designed and implemented by Xerox in 1975, and used continually since that time by thousands of stations. The Ethernet defined here builds on that experience, and on the larger base of the combined experience of Digital, Intel, and Xerox in many forms of networking and computer interconnection.

In specifying the Ethernet, this document provides precise detailed definitions of the lowest two layers of an overall network architecture. It thus defines what is generally

referred to as a *link-level* facility. It does not specify the higher level protocols needed to provide a complete network architecture. Such higher level protocols would generally include such functions as internetwork communication, error recovery, flow control, security measures (e.g. encryption), and other higher level functions that increase the power of the communication facility and/or tailor it to specific applications. In particular, it should be noted that all error recovery functions have been relegated to higher level protocols, in keeping with the low error rates that characterize local networks.

One of the main objectives of this specification is *compatibility*. As stated in Section 3, it is intended that *every implementation of the Ethernet be able to exchange data with every other implementation*. It should be noted that higher level protocols raise their own issues of compatibility over and above those addressed by the Ethernet and other link-level facilities. This does not eliminate the importance of link-level compatibility, however. While the compatibility provided by the Ethernet does not guarantee solutions to higher level compatibility problems, it does provide a context within which such problems can be addressed, by avoiding low level incompatibilities that would make direct communication impossible.

## 2. REFERENCES

*The following three papers describe the Experimental Ethernet, and are reprinted in: "The Ethernet Local Network: Three Reports," Xerox Palo Alto Research Center Technical Report CSL-80-2. (February, 1980.)*

- [1] Metcalfe, R. M. and Boggs, D. R., "Ethernet: Distributed Packet Switching for Local Computer Networks," *Communications of the ACM* 19 7 (July 1976).
- [2] Crane, R. C. and Taft, E. A. "Practical Considerations in Ethernet Local Network Design," Presented at *Hawaii International Conference on System Sciences* (January, 1980).
- [3] Shoch, J. F. and Hupp, J. A. "Measured Performance of an Ethernet Local Network," Presented at *Local Area Communications Network Symposium* Boston (May 1979).

*The following references describe the ISO Open Systems Model:*

- [4] Zimmermann, H., "OSI Reference Model -- The ISO Model of Architecture for Open Systems Interconnection," *IEEE Transactions on Communication COM-28* 4 (April 1980).
- [5] International Organization for Standardization (ISO), "Reference Model of Open Systems Interconnection," *Document no. ISO/TC97/SC16 N227* (June 1979).

*The following references describe the Pascal language (used in the Data Link Layer procedural model) and its derivative Concurrent Pascal:*

- [6] Jensen, K. and Wirth, N., *Pascal User Manual and Report, 2nd Edition.* Springer-Verlag (1974).
- [7] Brinch Hansen, P., *Concurrent Pascal Report.* Technical Report CIT-IS-TR 17, California Institute of Technology (1975).

*The following references discuss the CRC code used for the frame check sequence:*

- [8] Hammond, J. L., Brown, J. E. and Liu, S. S., "Development of a Transmission Error Model and an Error Control Model," Technical Report RADC-TR-75-138, Rome Air Development Center (1975).
- [9] Bittel, R., "On Frame Check Sequence (FCS) Generation and Checking.," ANSI working paper X3-S34-77-43, (1977).

### 3. GOALS AND NON-GOALS

This section states the assumptions underlying the design of the Ethernet.

#### 3.1 Goals

The goals of the Ethernet design are:

*Simplicity:* Features which would complicate the design without substantially contributing to the meeting of the other goals have been excluded.

*Low cost:* Since technological improvements will continue to reduce the overall cost of stations wishing to connect to the Ethernet, the cost of the connection itself should be minimized.

*Compatibility:* All implementations of the Ethernet should be capable of exchanging data at the data link level. For this reason, the specification avoids optional features, to eliminate the possibility of incompatible variants of the Ethernet.

*Addressing flexibility:* The addressing mechanisms should provide the capability to target frames to a single node, a group of nodes, or to all nodes on the network.

*Fairness:* All nodes should have equal access to the network when averaged over time.

*Progress:* No single node operating in accordance with the protocol should be able to prevent the progress of other nodes.

*High speed:* The network should operate efficiently at a data rate of 10 Megabits per second.

*Low delay:* At any given level of offered traffic, the network should introduce as little delay as possible in the transfer of a frame.

*Stability:* The network should be stable under all load conditions, in the sense that the delivered traffic should be a monotonically non-decreasing function of the total offered traffic.

*Maintainability:* The Ethernet design should allow for network maintenance, operation, and planning.

*Layered Architecture:* The Ethernet design should be specified in layered terms to separate the logical aspects of the data link protocol from the physical details of the communication medium.

### 3.2 Non-Goals

The following are *not* goals of the Ethernet design:

*Full duplex:* At any given instant, the Ethernet can transfer data from one source station to one or more destination stations. Bi-directional communication is provided by rapid exchange of frames, rather than full duplex operation.

*Error control:* Error handling at the data link level is limited to detection of bit errors in the physical channel, and the detection and recovery from collisions. Provision of a complete error control facility to handle detected errors is relegated to higher layers of the network architecture.

*Security:* The data link protocol does not employ encryption or other mechanisms to provide security. Higher layers of the network architecture may provide such facilities as appropriate.

*Speed flexibility:* This specification defines a physical channel operating at a single fixed data rate of 10 Megabits per second.

*Priority:* The data link protocol provides no support of priority station operation.

*Hostile user:* There is no attempt to protect the network from a malicious user at the data link level.



#### 4. FUNCTIONAL MODEL OF THE ETHERNET ARCHITECTURE

There are two important ways to view the Ethernet design, corresponding to:

*Architecture*, emphasizing the logical divisions of the system, and how they fit together.

*Implementation*, emphasizing the actual components, and their packaging and interconnection.

Figure 4-1 illustrates these two views as they apply to a typical implementation, showing how each view groups the various functions.

This document is organized along *architectural* lines, emphasizing the large-scale separation of the Ethernet system into two parts: the *Data Link Layer* and the *Physical Layer*. These layers are intended to correspond closely to the lowest layers of the ISO Model for Open Systems Interconnection [4,5]. Architectural organization of the specification has two main advantages:

*Clarity*: A clean overall division of the design along architectural lines makes the specification clearer.

*Flexibility*: Segregation of medium-dependent aspects in the Physical Layer allows the Data Link Layer to apply to transmission media other than the specified coaxial cable.

As is evident in Figure 4-1, the architectural model is based on a set of interfaces different from those emphasized in the implementations. One crucial aspect of the design, however, must be addressed largely in terms of the implementation interfaces: *compatibility*. Two important compatibility interfaces are defined within what is architecturally the Physical Layer:

*Coaxial cable interface*: To communicate via the Ethernet, all stations must adhere rigidly to the exact specification of coaxial cable signals defined in this document, and to the procedures which define correct behavior of a station. The medium-independent aspects of the Data Link Layer should not be taken as detracting from this point: *communication via the Ethernet requires complete compatibility at the coaxial cable interface*.

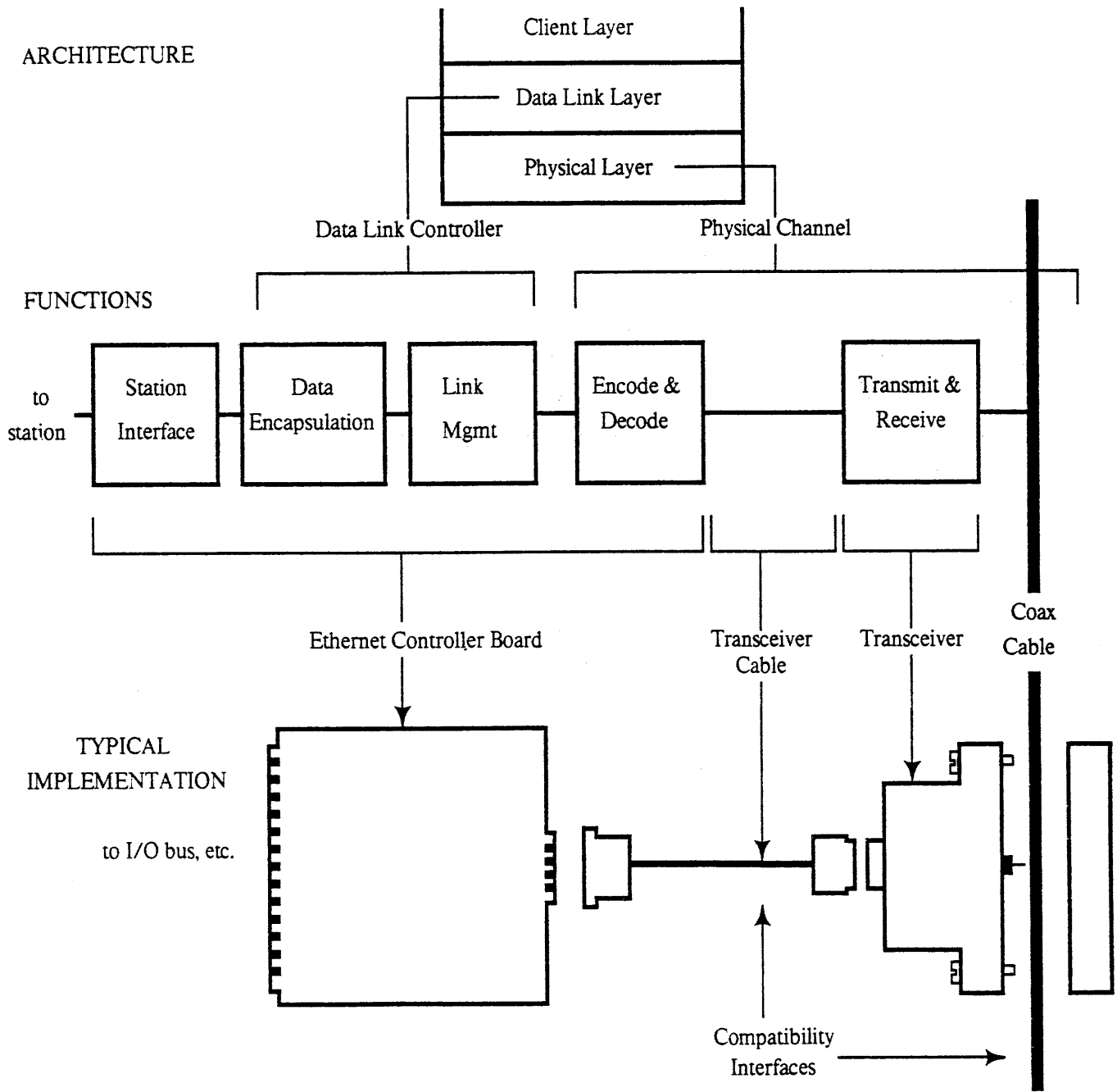

Figure 4-1: Ethernet Architecture and Typical Implementation

*Transceiver cable interface:* It is anticipated that most stations will be located some distance away from their connection to the coaxial cable. While it is necessary to place a small amount of circuitry (the *transceiver*) directly adjacent to the coaxial cable, the majority of the electronics (the *controller*) can and should be placed with the station. Since it is desirable for the same transceiver to be usable with a wide variety of stations, a second compatibility interface, the *transceiver cable interface*, is defined. While conformance with this interface is not strictly necessary to insure communication, it is highly recommended, since it allows maximum flexibility in intermixing transceivers and stations.

#### 4.1 Layering

The major division in the Ethernet Architecture is between the Physical Layer and the Data Link Layer, corresponding to the lowest two levels in the ISO model. The higher levels of the overall network architecture, which use the Data Link Layer, will be collectively referred to in this document as the "Client Layer" since, strictly speaking, the identity and function of higher level facilities are outside the scope of this specification. The intent, however, is that the Ethernet Physical and Data Link Layers support the higher layers of the ISO model (Network Layer, Transport Layer, etc.).

The overall structure of the layered architecture is shown in Figure 4-2.

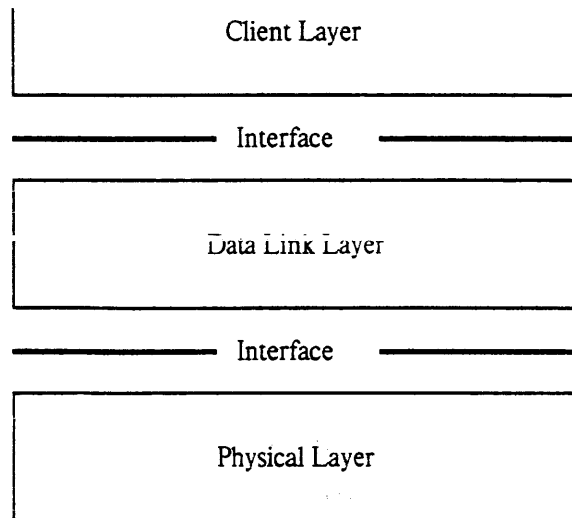

Figure 4-2: Architectural Layering

In the architectural model used here, the layers interact via well defined interfaces.

The interface between the Client Layer and the Data Link Layer includes facilities for transmitting and receiving frames, and provides per-operation status information for use by higher-level error recovery procedures.

The interface between the Data Link Layer and the Physical Layer includes signals for framing (carrier sense, transmit initiation) and contention resolution (collision detect), facilities for passing a pair of serial bit streams (transmit, receive) between the two layers, and a wait function for timing.

These interfaces are described more precisely in Section 5.

As mentioned in the preface, additional interfaces are necessary to allow a higher level network management facility to interact with the Data Link Layer and Physical Layer to perform operation, maintenance and planning functions.

## 4.2 Data Link Layer

The Data Link Layer defines a medium-independent link level communication facility, built on the medium-dependent physical channel provided by the Physical Layer. It is applicable to a general class of local area broadcast media suitable for use with the channel access discipline known as carrier-sense multiple-access with collision-detection (CSMA-CD). Compatibility with non-contention media (e.g., switched lines, token-passing rings, etc.), while a worthwhile topic for further research, is not addressed in this specification.

The Data Link Layer specified here is intended to be as similar as possible to that described in the ISO model. In a broadcast network like the Ethernet, the notion of a data link between two network entities does not correspond directly to a distinct physical connection. Nevertheless, the two main functions generally associated with a data link control procedure are present:

### *Data encapsulation*

- framing (frame boundary delimitation)
- addressing (handling of source and destination addresses)
- error detection (detection of physical channel transmission errors)

### *Link management*

- channel allocation (collision avoidance)
- contention resolution (collision handling)

This split is reflected in the division of the Data Link Layer into the Data Encapsulation sub-layer and the Link Management sub-layer, as shown in Figure 4-3.

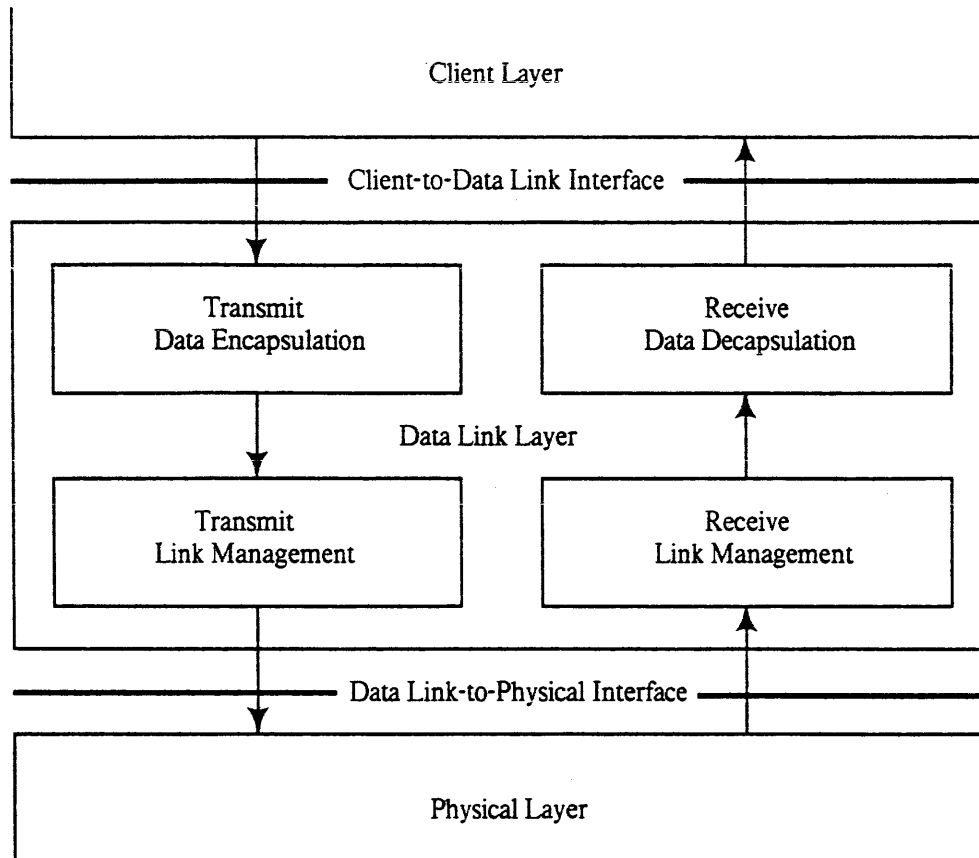

Figure 4-3: Data Link Layer Functions

In terms of the ISO model, the Ethernet Data Link Layer provides a multi-endpoint connection between higher-layer entities wishing to communicate. The connection provided is called a *data link*, and is implemented between two or more Data Link Layer entities called *data link controllers* via a Physical Layer connection called the *physical channel*.

### 4.3 Physical Layer

The Physical Layer specified in this document provides a 10 MBit/sec physical channel through a coaxial cable medium. Because one purpose of the layered architecture is to insulate the Data Link Layer from the medium-specific aspects of the channel, the Physical Layer completely specifies the essential physical characteristics of the Ethernet, such as data encoding, timing, voltage levels, etc. Implementation details are left unspecified, to retain maximum flexibility for the implementor. In all cases, the criterion applied in distinguishing between essential characteristics and implementation details is *guaranteed compatibility*: any two correct implementations of the Physical Layer specified here will be capable of exchanging data over the coaxial cable, enabling communication between their

respective stations at the Data Link Layer.

The Physical Layer defined in this specification performs two main functions generally associated with physical channel control:

*Data encoding*

- preamble generation/removal (for synchronization)
- bit encoding/decoding (between binary and phase-encoded form)

*Channel access*

- bit transmission/reception (of encoded data)
- carrier sense (indicating traffic on the channel)
- collision detection (indicating contention on the channel)

This split is reflected in the division of the Physical Layer into the Data Encoding sub-layer and the Channel Access sub-layer, as shown in Figure 4-4.

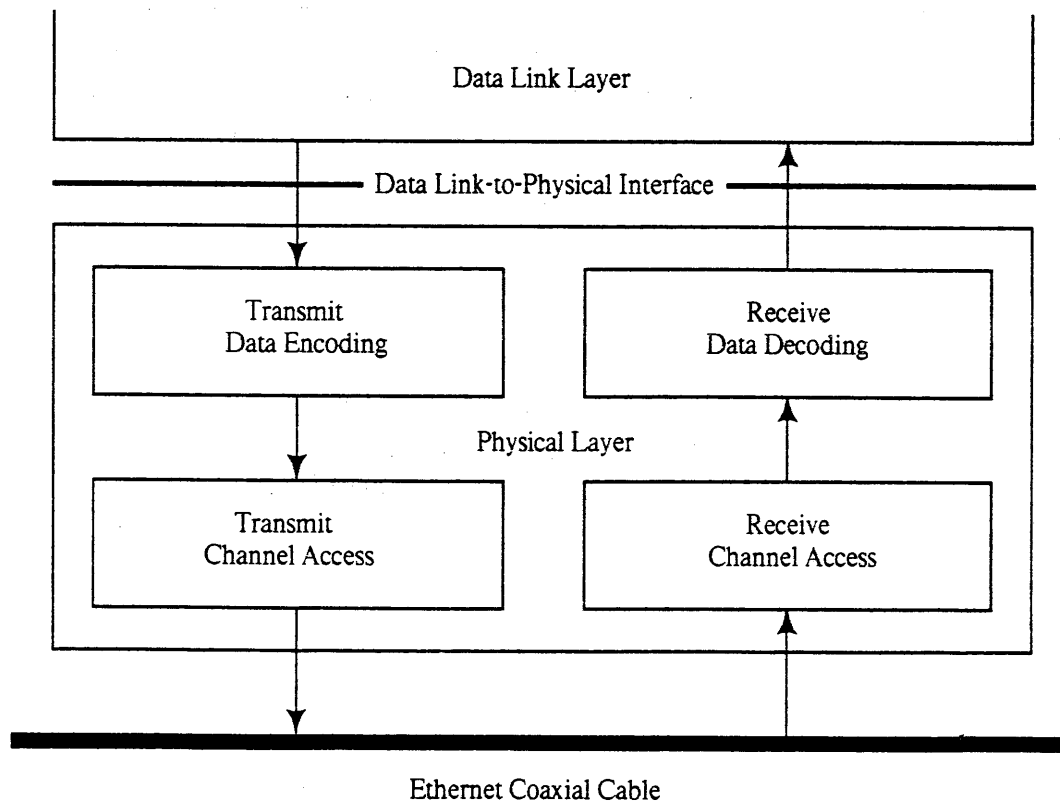

Figure 4-4: Physical Layer Functions

#### 4.4 Ethernet Operation and the Functional Model

This section provides an overview of frame transmission and reception in terms of the functional model of the architecture. This overview is descriptive, rather than definitional; the formal specifications of the operations described here are given in Sections 6 and 7.

##### 4.4.1 Transmission Without Contention

When the Client Layer requests the transmission of a frame, the Transmit Data Encapsulation component of the Data Link Layer constructs the frame from the client-supplied data and appends a frame check sequence to provide for error detection. The frame is then handed to the Transmit Link Management component for transmission.

Transmit Link Management attempts to avoid contention with other traffic on the channel by monitoring the *carrier sense* signal and *deferring* to passing traffic. When the channel is clear, frame transmission is initiated (after a brief interframe delay to provide recovery time for other data link controllers and for the physical channel). The Data Link Layer then provides a serial stream of bits to the Physical Layer for transmission.

The Data Encoding component of the Physical Layer, before sending the actual bits of the frame, sends an encoded preamble to allow the receivers and repeaters along the channel to synchronize their clocks and other circuitry. It then begins translating the bits of the frame into encoded form and passes them to the Channel Access component for actual transmission over the medium.

The Channel Access component performs the task of actually generating the electrical signals on the medium which represent the bits of the frame. Simultaneously, it monitors the medium and generates the *collision detect* signal, which, in the contention-free case under discussion, remains off for the duration of the frame.

When transmission has completed without contention, the Data Link Layer so informs the Client Layer and awaits the next request for frame transmission.

##### 4.4.2 Reception Without Contention

At the receiving station, the arrival of a frame is first detected by the Receive Channel Access component of the Physical Layer, which responds by synchronizing with the incoming preamble, and by turning on the carrier sense signal. As the encoded bits arrive from the medium, they are passed to the Receive Data Decoding component.

Receive Data Decoding translates the encoded signal back into binary data and discards the leading bits, up to and including the end of the preamble. It then passes subsequent bits up to the Data Link Layer.

Meanwhile, the Receive Link Management component of the Data Link Layer, having seen carrier sense go on, has been waiting for the incoming bits to be delivered. Receive Link Management collects bits from the Physical Layer as long as the carrier sense signal remains on. When the carrier sense signal goes off, the frame is passed to Receive Data Decapsulation for processing.

Receive Data Decapsulation checks the frame's destination address field to decide whether the frame should be received by this station. If so, it passes the contents of the frame to the Client Layer along with an appropriate status code. The status code is generated by inspecting the frame check sequence to detect any damage to the frame enroute, and by checking for proper octet-boundary alignment of the end of the frame.

#### 4.4.3 Collisions: Handling of Contention

If multiple stations attempt to transmit at the same time, it is possible for their transmitting data link controllers to interfere with each others' transmissions, in spite of their attempts to avoid this by deferring. When two stations' transmissions overlap, the resulting contention is called a *collision*. A given station can experience a collision during the initial part of its transmission (the "collision window"), before its transmitted signal has had time to propagate to all parts of the Ethernet channel. Once the collision window has passed, the station is said to have *acquired* the channel; subsequent collisions are avoided, since all other (properly functioning) stations can be assumed to have noticed the signal (via carrier sense) and to be deferring to it. The time to acquire the channel is thus based on the *round-trip propagation time* of the physical channel.

In the event of a collision, the Transmit Channel Access component of a transmitting station's Physical Layer first notices the interference on the channel and turns on the collision detect signal. This is noticed in turn by the Transmit Link Management component of the Data Link Layer, and collision handling begins. First, Transmit Link Management *enforces* the collision by transmitting a bit sequence called the *jam*. This insures that the duration of the collision is sufficient to be noticed by the other transmitting station(s) involved in the collision. After the jam is sent, Transmit Link Management terminates the transmission and schedules a retransmission attempt for a randomly selected time in the near future. Retransmission is attempted repeatedly in the face of repeated collisions. Since repeated collisions indicate a busy channel, however, Transmit Link Management attempts to adjust to the channel load by *backing off* (voluntarily delaying its own retransmissions to reduce its load on the channel). This is accomplished by



expanding the interval from which the random retransmission time is selected on each retransmission attempt. Eventually, either the transmission succeeds, or the attempt is abandoned on the assumption that the channel has failed or has become overloaded.

At the receiving end, the bits resulting from a collision are received and decoded by the Physical Layer just as are the bits of a valid frame. In particular, collisions do *not* turn on the receiving station's collision detect signal, which is generated only during transmission. Instead, the fragmentary frames received during collisions are distinguished from valid frames by the Data Link's Receive Link Management component, by noting that a collision fragment is always smaller than the shortest valid frame. Such fragments are discarded by Receive Link Management.

## 5. INTER-LAYER INTERFACES

The purpose of this section is to provide precise definitions of the interfaces between the architectural layers defined in Section 4. In order to provide such a definition, some precise notation must be adopted. The notation used here is the Pascal language, in keeping with the procedural nature of the formal Data Link Layer specification (see 6.5). Each interface is thus described as a set of procedures and/or shared variables which collectively provide the only valid interactions between layers. The accompanying text describes the meaning of each procedure or variable and points out any implicit interactions among them.

Note that the description of the interfaces in Pascal is a notational technique, and in no way implies that they can or should be implemented in software. This point is discussed more fully in 6.5, which provides complete Pascal declarations for the data types used in the remainder of this section. Note also that the "synchronous" (one frame at a time) nature of the frame transmission and reception operations is a property of the architectural interface between the Client Layer and the Data Link Layer, and need not be reflected in the implementation interface between a station and its controller.

### 5.1 Client Layer to Data Link Layer

The two primary services provided to the Client Layer by the Data Link Layer are transmission and reception of frames. The interface through which the Client Layer uses the facilities of the Data Link Layer therefore consists of a pair of functions.

Functions:

*TransmitFrame*

*ReceiveFrame*

Each of these functions has the components of a frame as its parameters (input or output), and returns a status code as its result.

The Client Layer transmits a frame by invoking *TransmitFrame*:

```
function TransmitFrame (  
  destinationParam: AddressValue;  
  sourceParam: AddressValue;  
  typeParam: TypeValue;  
  dataParam: DataValue): TransmitStatus;
```

The *TransmitFrame* operation is synchronous, in the sense that its duration is the entire attempt to transmit the frame, so that when the operation completes, transmission has either succeeded or failed, as indicated by the resulting status code:

```
type TransmitStatus = (transmitOK, excessiveCollisionError);
```

Successful transmission is indicated by the status code *transmitOK*; the code *excessiveCollisionError* indicates that the transmission attempt was aborted due to excessive collisions, because of heavy traffic or a network failure. Implementations may define additional implementation-dependent status codes if necessary.

The Client Layer accepts incoming frames by invoking *ReceiveFrame*:

```
function ReceiveFrame (  
    var destinationParam: AddressValue;  
    var sourceParam: AddressValue;  
    var typeParam: TypeValue;  
    var dataParam: DataValue): ReceiveStatus;
```

The *ReceiveFrame* operation is synchronous, in the sense that the operation does not complete until a frame has been received. The fields of the frame are delivered via the output parameters, along with a status code:

```
type ReceiveStatus = (receiveOK, frameCheckError, alignmentError);
```

Successful reception is indicated by the status code *receiveOK*. The code *frameCheckError* indicates that the frame received was damaged by a transmission error in the physical channel. The code *alignmentError* indicates that the frame received was damaged, and that in addition, its length was not an integral number of octets. Implementations may define additional implementation-dependent status codes if necessary.

## 5.2 Data Link Layer to Physical Layer

The interface through which the Data Link Layer uses the facilities of the Physical Layer consists of a function, a pair of procedures and three Boolean variables.

Function:	Variables:
<i>ReceiveBit</i>	<i>collisionDetect</i>
Procedures:	<i>carrierSense</i>
<i>TransmitBit</i>	<i>transmitting</i>
<i>Wait</i>	

During transmission, the contents of an outgoing frame are passed from the Data Link Layer to the Physical Layer via repeated use of the *TransmitBit* operation:

```
procedure TransmitBit (bitParam: Bit);
```

Each invocation of *TransmitBit* passes one new bit of the outgoing frame to the Physical Layer. The *TransmitBit* operation is synchronous, in the sense that the duration of the operation is the entire transmission of the bit, so that when the operation completes, the Physical Layer is ready to accept the next bit immediately. (Note: this does not imply that all invocations of *TransmitBit* are of exactly equal duration; for example, if the Physical Layer must perform some initial processing -- e.g., preamble generation -- before transmitting the first bit of a frame, the first

invocation of *TransmitBit* may take significantly longer.)

The overall event of data being transmitted is signaled to the Physical Layer via the variable *transmitting*:

```
var transmitting: Boolean;
```

Before sending the first bit of a frame, the Data Link Layer sets *transmitting* to *true*, to inform the Physical Link that a stream of bits will be presented via the *TransmitBit* operation. After the last bit of the frame has been presented, the Data Link Layer sets *transmitting* to *false* to indicate the end of the frame.

The presence of a collision in the physical channel is signaled to the Data Link Layer via the variable *collisionDetect*:

```
var collisionDetect: Boolean;
```

The *collisionDetect* signal remains *true* during the duration of the collision. (Note: Since an entire collision may occur during the first invocation of *TransmitBit* -- e.g., during preamble removal -- the Data Link Layer must handle this possibility by monitoring *collisionDetect* concurrently with its transmission of outgoing bits. See 6.5 for details.)

The *collisionDetect* signal is generated only during transmission and is never *true* at any other time; in particular, it cannot be used during frame reception to detect collisions between overlapping transmissions from two or more other stations.

During reception, the contents of an incoming frame are retrieved from the Physical Layer by the Data Link Layer via repeated use of the *ReceiveBit* operation:

```
function ReceiveBit: Bit;
```

Each invocation of *ReceiveBit* retrieves one new bit of the incoming frame (i.e., not including any preamble bits) from the Physical Layer. The *ReceiveBit* operation is synchronous, in the sense that its duration is the entire reception of a single bit. (As with *TransmitBit*, the first invocation of *ReceiveBit* may take significantly longer -- e.g., due to preamble removal). Upon receiving a bit, the Data Link Layer must immediately request the next bit until all bits of the frame have been received. (See 6.5 for details.)

The overall event of data being received is signaled to the Data Link Layer via the variable *carrierSense*:

```
var carrierSense: Boolean;
```

When the Physical Layer sets *carrierSense* to *true*, the Data Link Layer must immediately begin retrieving the incoming bits via the *ReceiveBit* operation. When *carrierSense* subsequently becomes *false*, the Data Link Layer can begin processing the received bits as a completed frame. Note that the *true/false*

transitions of *carrierSense* are not defined to be precisely synchronized with the beginning and end of the frame, but may precede the beginning and lag the end, respectively. If an invocation of *ReceiveBit* is pending when *carrierSense* becomes *false*, *ReceiveBit* returns an undefined value, which should be discarded by the Data Link Layer. (See 6.5 for details.)

The Data Link Layer must also monitor the value of *carrierSense* to defer its own transmissions when the channel is busy.

The Physical Layer also provides the procedure *Wait*:

**procedure** *Wait* (*bitTimes*: integer);

This procedure waits for the specified number of bit times. This allows the Data Link Layer to measure time intervals in units of the (physical-channel-dependent) bit time.

Another important property of the Physical Layer which is an implicit part of the interface presented to the Data Link Layer is the *round-trip propagation time* of the physical channel. This figure represents the maximum time required for a signal to propagate from one end of the network to the other, and for a collision to propagate back. The round-trip propagation time is primarily (but not entirely) a function of the physical size of the network. The round-trip propagation time of the Physical Layer is defined to be at most 450 bit times (see 7.1.2).

## 6. ETHERNET DATA LINK LAYER SPECIFICATION

### 6.1 Data Link Layer Overview and Model

As defined in Section 4, the Ethernet Architecture consists of the Data Link Layer, and below it, the Physical Layer. Furthermore, the Data Link Layer is divided into two sub-layers (see Figure 4-3).

#### Data encapsulation

- framing
- addressing
- error detection

#### Link management

- channel allocation
- contention resolution

This model is used throughout this section to structure the detailed specification of the Data Link Layer. An English description of the Data Link Layer is given in 6.2, 6.3, and 6.4. A more precise algorithmic definition is given in 6.5, which provides a procedural model for the Data Link Layer in the form of a program in the language Pascal. Note that whenever there is any apparent ambiguity concerning the definition of some aspect of the Data Link Layer, it is the Pascal procedural specification in 6.5 which should be consulted for the definitive statement.

### 6.2 Frame Format

The data encapsulation function of the Data Link Layer comprises the construction and processing of frames. The subfunctions of framing, addressing, and error detection are reflected in the frame format as follows:

*Framing:* No explicit framing information is needed, since the necessary framing cues (*carrierSense* and *transmitting*) are present in the interface to the Physical Layer.

*Addressing:* Two address fields are provided to identify the source and destination stations for the frame.

*Error detection:* A Frame Check Sequence field is provided for detection of transmission errors.

Figure 6-1 shows the five fields of a frame: the addresses of the frame's source and destination, a type field for use by higher layers (see 6.2.2), a data field containing the transmitted data, and the frame check sequence field containing a cyclic redundancy check value to detect transmission errors. Of these five fields, all are of fixed size except the data field, which may contain any integral number of octets between the minimum and maximum values specified below (see 6.2.5).

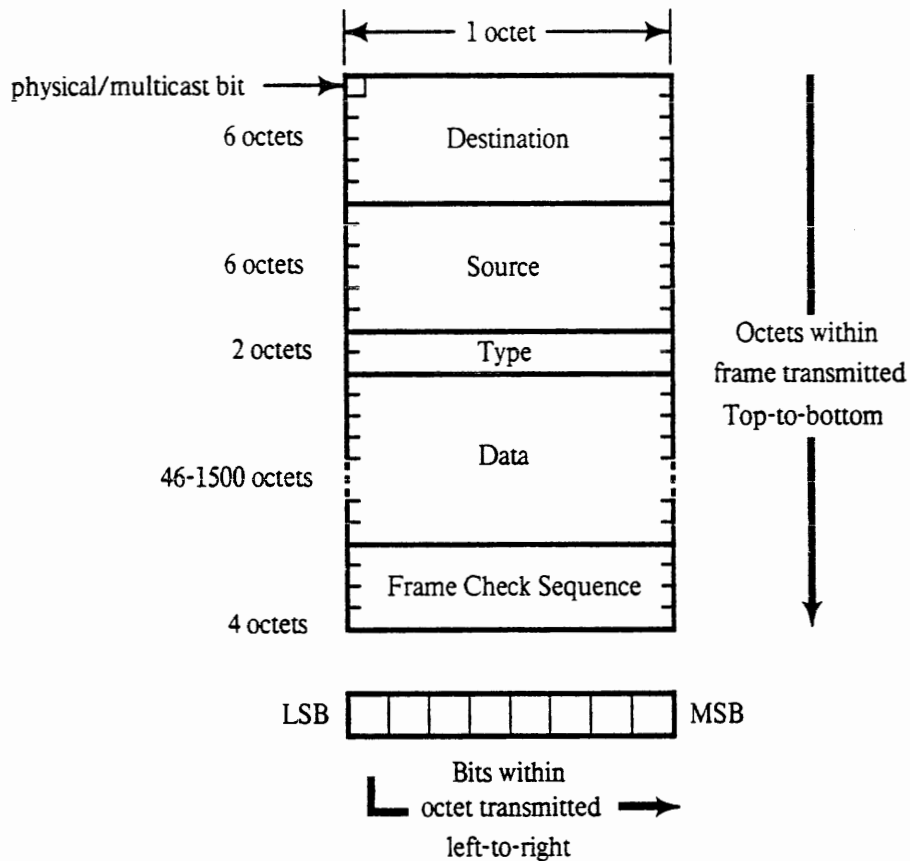

Figure 6-1: Data Link Layer Frame Format

Relative to Figure 6-1, the octets of a frame are transmitted from top to bottom, and the bits of each octet are transmitted from left to right.

## NOTE

This document does *not* define an order of transmission for the octets of standard multi-octet data types (strings, integers, etc), since no values of such data types appear in the data link frame format. The order in which implementations of the Ethernet store the octets of a frame in computer memory, and the manner in which higher level protocols interpret the contents of the data field as values of various multi-octet data types, are beyond the scope of this specification.

The Ethernet itself is also totally insensitive to the interpretation of bits within a octet as constituting the digits of an 8-digit binary numeric value. Since some uniform convention is helpful, however, in avoiding needless incompatibility among different station types, the interpretation is arbitrarily defined to be that the left-most bit (first transmitted) is the low-order ( $2^0$ ) digit and the right-most bit (last transmitted) is the high-order ( $2^7$ ) digit.

### 6.2.1 Address Fields

Data link addresses are 6 octets (48 bits) in length. A data link address is of one of two types:

*Physical address:* The unique address associated with a particular station on the Ethernet. A station's physical address should be distinct from the physical address of any other station on *any* Ethernet.

*Multicast address:* A multi-destination address, associated with one or more stations on a given Ethernet. There are two kinds of multicast address:

- *Multicast-group address:* An address associated by higher-level convention with a group of logically related stations.
- *Broadcast address:* A distinguished, predefined multicast address which always denotes the set of *all* stations on a given Ethernet.

The first bit of a data link address distinguishes physical from multicast addresses:

0 ⇒ physical address

1 ⇒ multicast address

In either case, the remainder of the first octet and all of the subsequent octets form a 47-bit pattern. In the case of the broadcast address, this pattern consists of 47 one-bits. There is no standard "null" address value.

The procedures for assigning suitably unique values for physical and multicast addresses are discussed in Appendix B.

#### 6.2.1.1 Destination Address Field

The destination address field specifies the station(s) for which the frame is intended. It may be a physical or multicast (including broadcast) address. For details of address recognition by the receiving station(s), see 6.4.1.2.

#### 6.2.1.2 Source Address Field

The source address field specifies the station sending the frame. The source address field is not interpreted at the Data Link Layer. It is specified at the data link level because a uniform convention for the placement of this field is crucial for most higher level protocols.

### 6.2.2 Type Field

The type field consists of a two-octet value reserved for use by higher levels (in particular, to identify the Client Layer protocol associated with the frame). The type field is uninterpreted at the Data Link Layer. It is specified at this level because a uniform convention for the placement and value assignment of this field is crucial if multiple higher level protocols are to be able to share the same Ethernet network without conflict. Appendix B discusses the assignment of type field values.



### 6.2.3 Data Field

The data field contains a sequence of  $n$  octets, where  $46 \leq n \leq 1500$ . Within this range, full data transparency is provided, in the sense that any arbitrary sequence of octet values may appear in the data field.

### 6.2.4 Frame Check Sequence Field

The frame check sequence (FCS) field contains a 4-octet (32-bit) cyclic redundancy check (CRC) value. This value is computed as a function of the contents of the source, destination, type and data fields (i.e., all fields except the frame check sequence field itself). The encoding is defined by the generating polynomial:

$$G(x) = x^{32} + x^{26} + x^{23} + x^{22} + x^{16} + x^{12} + x^{11} + x^{10} + x^8 + x^7 + x^5 + x^4 + x^2 + x + 1$$

(This polynomial is also used in the Autodin-II network; its properties are investigated in [8].)

Mathematically, the CRC value corresponding to a given frame is defined by the following procedure:

1. The first 32 bits of the frame are complemented.
2. The  $n$  bits of the frame are then considered to be the coefficients of a polynomial  $M(x)$  of degree  $n-1$ . (The first bit of the destination address field corresponds to the  $x^{n-1}$  term and the last bit of the data field corresponds to the  $x^0$  term.)
3.  $M(x)$  is multiplied by  $x^{32}$  and divided by  $G(x)$ , producing a remainder  $R(x)$  of degree  $\leq 31$ .
4. The coefficients of  $R(x)$  are considered to be a 32-bit sequence.
5. The bit sequence is complemented and the result is the CRC.

The 32 bits of the CRC value are placed in the frame check sequence field so that the  $x^{31}$  term is the leftmost bit of the first octet, and the  $x^0$  term is the rightmost bit of the last octet. (The bits of the CRC are thus transmitted in the order  $x^{31}, x^{30}, \dots, x^1, x^0$ .)

Appendix C discusses CRC implementation issues.

### 6.2.5 Frame Size Limitations

Given the limitations on the size of the data field specified in 6.2.3 and the 18 octet total size for the other four fields, the smallest valid frame contains 64 octets and the largest valid frame contains 1518 octets.

## 6.3 Frame Transmission

The Data Link frame transmission and reception are as follows:

Frame transmission includes data encapsulation and link management aspects:

*Transmit Data Encapsulation* includes the assembly of the outgoing frame (from the values provided by the Client Layer) and frame check sequence generation.

*Transmit Link Management* includes carrier deference, interframe spacing, collision detection and enforcement, and collision backoff and retransmission.

The performance of these functions by a transmitting data link controller interacts with corresponding actions by other data link controllers to jointly implement the Ethernet data link protocol.

### 6.3.1 Transmit Data Encapsulation

#### 6.3.1.1 Frame Assembly

The fields of the data link frame are set to the values provided by the Client Layer as arguments to the *TransmitFrame* operation (see 5.1), with the exception of the frame check sequence, which is set to the CRC value generated by the data link controller.

#### 6.3.1.2 Frame Check Sequence Generation

The CRC value defined in 6.2.4, is generated and inserted in the frame check sequence field, following the fields supplied by the Client Layer. Appendix C discusses CRC implementation.

### 6.3.2 Transmit Link Management

#### 6.3.2.1 Carrier Deference

Even when it has nothing to transmit, the data link controller monitors the physical channel for traffic by watching the *carrierSense* signal provided by the Physical Layer. Whenever the channel is busy, the data link controller *defers* to the passing frame by delaying any pending transmission of its own. After the last bit of the passing frame (i.e., when *carrierSense* changes from true to false), the data link controller continues to defer for 9.6  $\mu$ sec to provide proper interframe spacing (see 6.3.2.2). At the end of that time, if it has a frame waiting to be transmitted, transmission is initiated independent of the value of *carrierSense*. When transmission has completed (or immediately, if there was nothing to transmit) the data link controller resumes its original monitoring of *carrierSense*.

When a frame is submitted by the Client Layer for transmission, the transmission is initiated as soon as possible, but in conformance with the rules of deference stated above.

### 6.3.2.2 Interframe Spacing

As defined in 6.3.2.1, the rules for deferring to passing frames insure a minimum interframe spacing of 9.6  $\mu$ sec. This is intended to provide interframe recovery time for other data link controllers and for the physical channel.

Note that 9.6  $\mu$ sec is the minimum value of the interframe spacing. If necessary for implementation reasons, a transmitting controller may use a larger value with a resulting decrease in its throughput. The value should not exceed 10.6  $\mu$ sec.

### 6.3.2.3 Collision Handling

Once a data link controller has finished deferring and has started transmission, it is still possible for it to experience contention for the channel. As discussed in 4.4.3, collisions can occur until acquisition of the network has been accomplished through the deference of all other stations' data link controllers.

The dynamics of collision handling are largely determined by a single parameter called the *slot time*. This single parameter describes three important aspects of collision handling:

- It is an upper bound on the acquisition time of the network.
- It is an upper bound on the length of a frame fragment generated by a collision. (See 6.4.2.1)
- It is the scheduling quantum for retransmission. (See 6.3.2.3.2)

In order to fulfill all three functions, the slot time must be larger than the sum of the Physical Layer round-trip propagation time (450 bit times; see 7.1.2) and the Data Link Layer maximum jam time (48 bit times, see 6.3.2.3.1). The slot time is defined to be 512 bit times.

#### 6.3.2.3.1 Collision Detection and Enforcement

Collisions are detected by monitoring the *collisionDetect* signal provided by the Physical Layer. When a collision is detected during a frame transmission, the transmission is not terminated immediately. Instead, the transmission continues until at least 32 (but not more than 48) additional bits have been transmitted (counting from the time *collisionDetect* went on). This collision enforcement or "jam" guarantees that the duration of the collision is sufficient to insure its detection by all transmitting stations on the network. The content of the jam is unspecified; it may be any fixed or variable pattern convenient to the data link controller implementation, but should not be the 32-bit CRC value corresponding to the (partial) frame transmitted prior to the jam.

### 6.3.2.3.2 Collision Backoff and Retransmission

When a transmission attempt has terminated due to a collision, it is retried by the transmitting data link controller until either it is successful, or 16 attempts (the original attempt plus 15 retries) have been made and all have terminated due to collisions. Note that all attempts to transmit a given frame are completed before any subsequent outgoing frames are transmitted. The scheduling of the retransmissions is determined by a controlled randomization process called "truncated binary exponential backoff". At the end of enforcing a collision (jamming), the data link controller delays before attempting to retransmit the frame. The delay is an integral multiple of the slot time. (See 6.3.2.3). The number of slot times to delay before the  $n^{\text{th}}$  retransmission attempt is chosen as a uniformly distributed random integer  $r$  in the range  $0 \leq r < 2^k$  where  $k = \min(n, 10)$ . If all 16 attempts fail, this event is reported as an error.

Note that the values given above define the most aggressive behavior that a station may exhibit in attempting to retransmit after a collision. In the course of implementing the retransmission scheduling procedure, a station may introduce extra delays which will degrade its own throughput, but in no case may a station's retransmission scheduling result in a lower average delay between retransmission attempts than the procedure defined above.

## 6.4 Frame Reception

Frame reception includes both data decapsulation and link management aspects:

*Receive Data Decapsulation* comprises framing, address recognition, frame check sequence validation, and frame disassembly to pass the fields of the received frame to the Client Layer.

*Receive Link Management's* main function is the filtering of collision fragments from complete incoming frames.

The performance of these functions by a receiving data link controller interacts with corresponding actions by other data link controllers to jointly implement the Ethernet data link protocol.

### 6.4.1 Receive Data Decapsulation

#### 6.4.1.1 Framing

The data link controller recognizes the boundaries of an incoming frame by monitoring the *carrierSense* signal provided by the Physical Layer. There are two possible length errors that can occur, which indicate ill-framed data: the frame may be too long, or its length may not be an integral number of octets.

#### 6.4.1.1.1 Maximum Frame Size

The receiving data link controller is not required to enforce the frame size limit specified in 6.2.5, but it is allowed to truncate frames longer than 1518 octets and report this event as an (implementation-dependent) error.

#### 6.4.1.1.2 Integral Number of Octets in Frame

Since the format of a valid frame specifies an integral number of octets, only a collision or an error can produce a frame with a length that is not an integral multiple of 8. Complete frames (i.e., not rejected as collision fragments; see 6.4.2.1) that do not contain an integral number of octets are truncated to the nearest octet boundary. If frame check sequence validation (see 6.4.1.3) detects an error in such a frame, the status code *alignmentError* is reported.

#### 6.4.1.2 Address Recognition

The Ethernet data link controller is capable of recognizing physical and multicast addresses, as defined in 6.2.1.

##### 6.4.1.2.1 Physical Addresses

The data link controller recognizes and accepts any frame whose destination field contains the physical address of the station.

The physical address of each station is set by network management to a unique value associated with the station, and distinct from the address of any other station on any Ethernet. The setting of the station's physical address by network management allows multiple data link controllers connected to single station all to respond to the same physical address. The procedures for allocating unique addresses are discussed in Appendix B.

##### 6.4.1.2.2 Multicast Addresses

The data link controller recognizes and accepts any frame whose destination field contains the broadcast address.

The data link controller is capable of activating some number of multicast-group addresses as specified by higher layers. The data link controller recognizes and accepts any frame whose destination field contains an active multicast-group address. An active multicast-group address may be deactivated.

#### 6.4.1.3 Frame Check Sequence Validation

FCS validation is essentially identical to FCS generation. If the bits of the incoming frame (exclusive of the FCS field itself) do not generate a CRC value identical to the one received, an error has occurred and is reported as such. Implementation issues are discussed in Appendix C.

#### 6.4.1.4 Frame Disassembly

The frame is disassembled and the fields are passed to the Client Layer via the output parameters of the *ReceiveFrame* operation (see 5.1).

### 6.4.2 Receive Link Management

#### 6.4.2.1 Collision Filtering

As specified in 6.2.5, the smallest valid frame must contain at least 64 octets. Any frame containing less than 64 octets is presumed to be a fragment resulting from a collision and is discarded by the receiving data link controller. Since occasional collisions are a normal part of the link management procedure, the discarding of such a fragment is not reported as an error to the Client Layer.

## 6.5 The Data Link Layer Procedural Model

### 6.5.1 Overview of the Procedural Model

The functions of the Ethernet Data Link Layer are presented below, modeled as a program written in the language Pascal [6]. This procedural model is intended as the primary specification of the functions to be provided in any Ethernet Data Link Layer implementation. It is important to distinguish, however, between the model and a real implementation. The model is optimized for simplicity and clarity of presentation, while any realistic implementation must place heavier emphasis on such constraints as efficiency and suitability to a particular implementation technology or computer architecture. In this context, several important properties of the procedural model must be considered.

#### 6.5.1.1 Ground Rules for the Procedural Model

- a) First, it must be emphasized that the description of the Data Link Layer in a programming language is in no way intended to imply that a data link controller must be implemented as a program executed by a computer. The implementation may consist of any appropriate technology including hardware, firmware, software, or any combination.
- b) Similarly, it must be emphasized that it is the *behavior* of Data Link Layer implementations that must match the specification, *not* their internal structure. The internal details of the procedural model are useful only to the extent that they help specify that behavior clearly and precisely.

- c) The handling of incoming and outgoing frames is rather stylized in the procedural model, in the sense that frames are handled as single entities by most of the Data Link Layer and are only serialized for presentation to the Physical Layer. In reality, many data link controller implementations will instead handle frames serially on a bit, octet or word basis. A serial implementation would typically perform the required functions (address recognition, frame check sequence generation/validation, etc.) in an overlapped, pipelined fashion. This approach has not been reflected in the procedural model, since this would only complicate the description of the functions without changing them in any way.
- d) The model consists of algorithms designed to be executed by a number of concurrent processes; these algorithms collectively implement the Ethernet data link control procedure. The timing dependencies introduced by the need for concurrent activity are resolved in two ways:

- *Processes vs. External events:* It is assumed that the algorithms are executed "very fast" relative to external events, in the sense that a process never falls behind in its work and fails to respond to an external event in a timely manner. For example, when a frame is to be received, it is assumed that the data link procedure *ReceiveFrame* is always called well before the frame in question has started to arrive.

- *Processes vs. Processes:* Among processes, no assumptions are made about relative speeds of execution. This means that each interaction between two processes must be structured to work correctly independent of their respective speeds. Note, however, that the timing of interactions among processes is often, in part, an indirect reflection of the timing of external events, in which case appropriate timing assumptions may still be made.

It is intended that the concurrency in the model reflect the parallelism intrinsic to the task of implementing the Ethernet data link, although the actual parallel structure of the implementations is likely to vary.

### 6.5.1.2 Use of Pascal in the Procedural Model

Pascal was chosen for the procedural model because of its relative simplicity and clarity, and its general acceptance.

Several observations need to be made about the way in which Pascal is used for the model, including:

a) Some limitations of the language have been circumvented in order to simplify the specification:

1) The elements of the program (variables, procedures, etc) are presented in logical groupings, in top-down order. Certain Pascal ordering restrictions have thus been circumvented to improve readability.

2) The **process** and **cycle** constructs of the Pascal derivative Concurrent Pascal [7] have been introduced to indicate the sites of autonomous concurrent activity. As used here, a process is simply a parameterless procedure that begins execution at "the beginning of time" rather than being invoked by a procedure call. A cycle statement represents the main body of a process and is executed repeatedly forever.

3) The lack of variable array bounds in the language has been circumvented by treating frames as if they are always of a single fixed size (which is never actually specified). In fact, of course, the size of a frame depends on the size of its data field, hence the value of the "pseudo-constant" *frameSize* should be thought of as varying in the long-term, even though it is fixed for any given frame.

4) The use of a variant record to represent a frame (both as fields and as bits) follows the letter but not the spirit of the Pascal Report, since it allows the underlying representation to be viewed as two different data types. (It also assumes that this representation is as shown in Figure 6-1.)

b) The model makes no use of any explicit interprocess synchronization primitives. Instead, all interprocess interaction is done via carefully stylized manipulation of shared variables. For example, some variables are set by only one process and inspected by another process in such a manner that the net result is independent of their execution speeds. While such techniques are not generally suitable for the construction of large concurrent programs, they simplify the model and more nearly resemble the methods appropriate to the most likely implementation technologies (e.g. microcode, hardware state-machines, etc.)



### 6.5.2 Procedural Model

The procedural model used here is based on five cooperating concurrent processes. Of these, three are actually defined in the Data Link Layer. The remaining two processes are provided by the Client Layer and utilize the interface operations provided by the Data Link Layer. The five processes are thus:

*Client Layer:*

**Frame Transmitter Process    Frame Receiver Process**

*Data Link Layer:*

**Bit Transmitter Process    Bit Receiver Process**

**Deference Process**

This organization of the model is illustrated in Figure 6-2, and reflects the fact that the communication of entire frames is initiated by the Client Layer, while the timing of collision backoff and of individual bit transfers is based on interactions between the Data Link Layer and the Physical-Layer-dependent bit-time.

Figure 6-2 depicts the static structure of the procedural model, showing how the various processes and procedures interact by invoking each other. Figures 6-3 and 6-4 summarize the dynamic behavior of the model during transmission and reception, focusing on the steps that must be performed, rather than the procedural structure which performs them. The usage of the shared state variables is not depicted in the figures, but is described in the comments in 6.5.2.1.

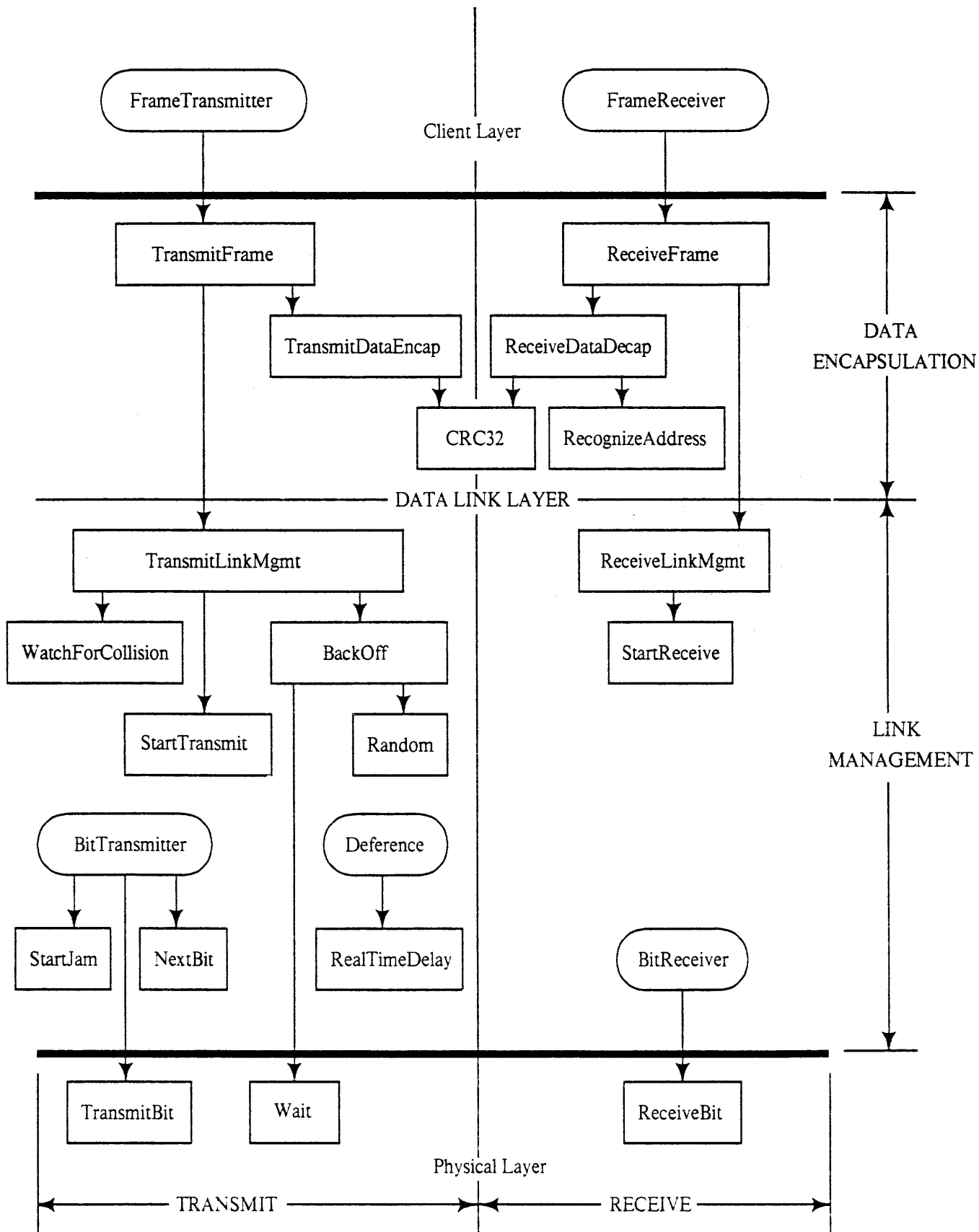

Figure 6-2: Structure of the Data Link Procedural Model

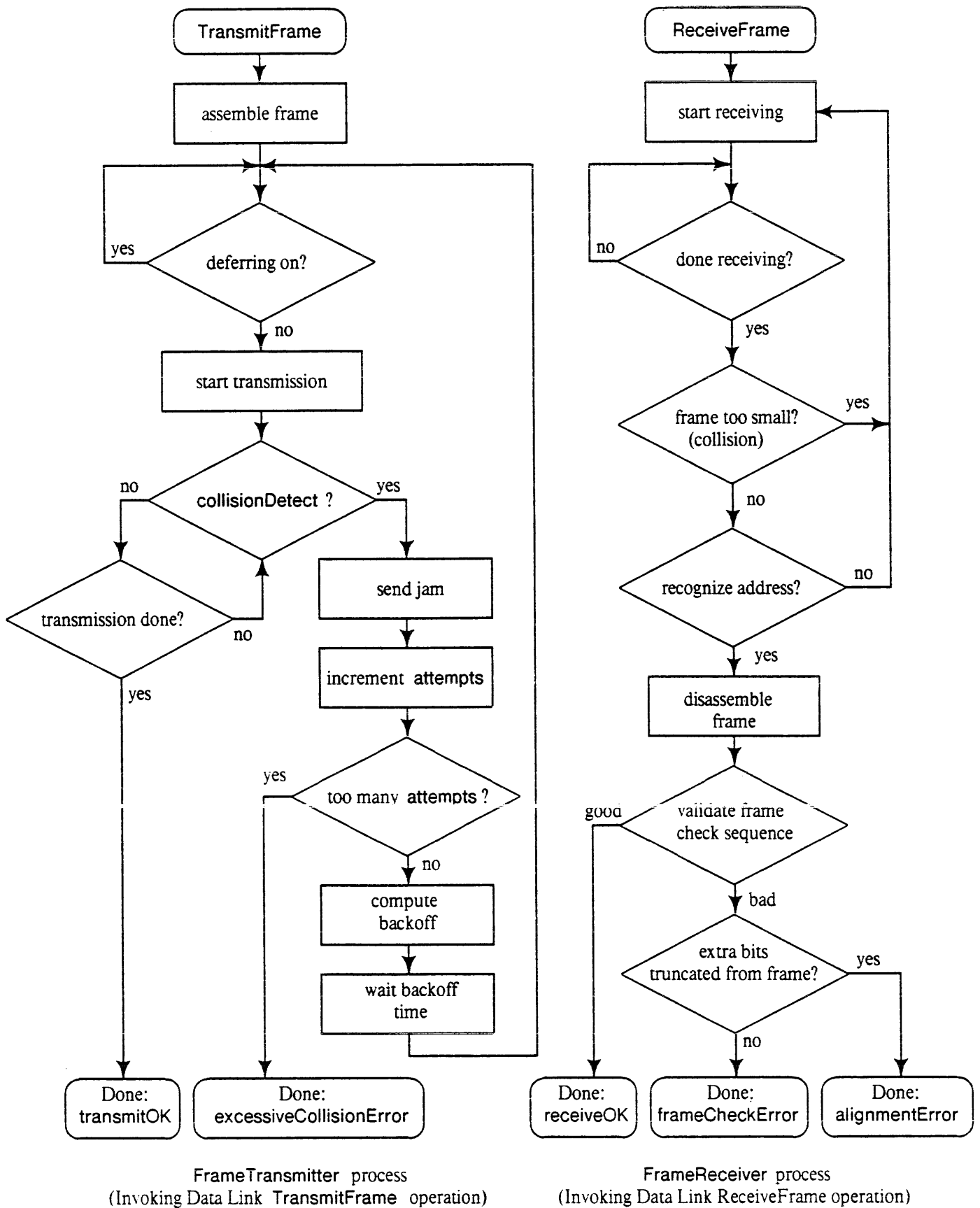

Figure 6-3: Control Flow Summary -- Client Layer Processes

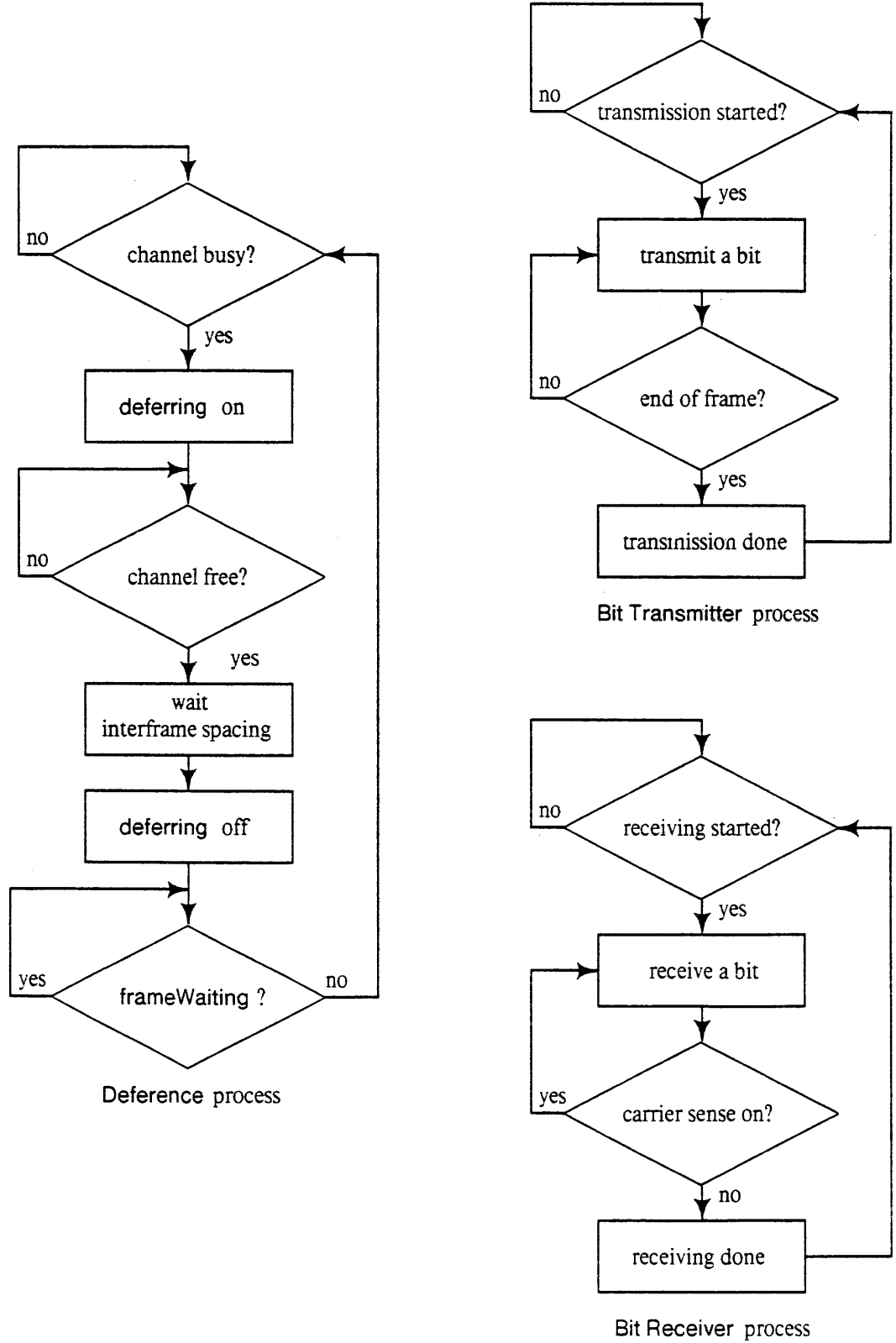

Figure 6-4: Control Flow Summary -- Data Link Layer Processes

### 6.5.2.1 Global Declarations

#### 6.5.2.1.1 Common Constants and Types

The following declarations of constants and types are used by the frame transmission and reception sections of each data link controller:

##### const

```

addressSize = 48; {48 bit address = 6 octets}
typeSize = 16; {16 bit protocol type = 2 octets}
dataSize = ...; {see 6.5.1.2, note 3}
crcSize = 32; {32 bit CRC = 4 octets}
frameSize = ...; { = 2*addressSize + typeSize + dataSize + crcSize...see 6.5.1.2,
note 3}

slotTime = 512; {unit of time for collision handling}

```

##### type

```

Bit = 0..1;
AddressValue = array [1..addressSize] of Bit;
TypeValue = array [1..typeSize] of Bit;
DataValue = array [1..dataSize] of Bit;
CRCValue = array [1..crcSize] of Bit;

ViewPoint = (fields, bits); {Two ways to view the contents of a frame}

Frame = record {Format of data link frame}
  case view: ViewPoint of
    fields: (
      destinationField: AddressValue;
      sourceField: AddressValue;
      typeField: TypeValue;
      dataField: DataValue;
      fcsField: CRCValue);
    bits: (
      contents: array [1..frameSize] of Bit)
  end; {Frame}

```

### 6.5.2.1.2 Transmit State Variables

The following items are specific to frame transmission. (See also 6.5.2.1.4 on interfaces)

#### const

```
interFrameSpacing = 9.6; {minimum time between frames, in microseconds}
attemptLimit = 16; {Max number of times attempt transmission}
backOffLimit = 10; {Limit on number of times to back off}
jamSize = 32; {jam may be 32 to 48 bits long}
```

#### var

```
outgoingFrame: Frame; {The frame to be transmitted}
currentTransmitBit, lastTransmitBit: 1..frameSize; {Positions of current and
last outgoing bits in outgoingFrame}
deferring: Boolean; {True implies any pending transmission must wait for the
channel to clear}
frameWaiting: Boolean; {Indicates that outgoingFrame is deferring}
attempts: 0..attemptLimit; {Number of transmission attempts on outgoingFrame}
newCollision: Boolean; {Indicates that a collision has occurred but has not yet
been jammed}
transmitSucceeding: Boolean; {Running indicator of whether transmission is
succeeding}
```

### 6.5.2.1.3 Receive State Variables

The following items are specific to frame reception. (See also 6.5.2.1.4 on interfaces)

#### var

```
incomingFrame: Frame; {The frame being received}
currentReceiveBit: 1..frameSize; {Position of current bit in incomingFrame}
receiving: Boolean; {Indicates that a frame reception is in progress}
excessBits: 0..7; {Count of excess trailing bits beyond octet boundary}
receiveSucceeding: Boolean; {Running indicator of whether reception is
succeeding}
```

#### 6.5.2.1.4 Summary of Interlayer Interfaces

The interface to the Client Layer, defined in 5.1, is summarized below:

**type**

TransmitStatus = (transmitOK, excessiveCollisionError); *{Result of TransmitFrame operation}*

ReceiveStatus = (receiveOK, frameCheckError, alignmentError); *{Result of ReceiveFrame operation}*

**function** TransmitFrame (

destinationParam: AddressValue;

sourceParam: AddressValue;

typeParam: typeValue;

dataParam: DataValue): TransmitStatus; *{Transmits one frame}*

**function** ReceiveFrame (

var destinationParam: AddressValue;

var sourceParam: AddressValue;

var typeParam: TypeValue;

var dataParam: DataValue): ReceiveStatus; *{Receives one frame}*

The interface to the Physical Layer, defined in 5.2, is summarized below:

**var**

carrierSense: Boolean; *{Indicates incoming bits}*

transmitting: Boolean; *{Indicates outgoing bits}*

collisionDetect: Boolean; *{Indicates channel contention}*

**procedure** TransmitBit (bitParam: Bit); *{Transmits one bit}*

**function** ReceiveBit: Bit; *{Receives one bit}*

**procedure** Wait (bitTimes: integer); *{Waits for indicated number of bit-times}*

### 6.5.2.1.5 State Variable Initialization

The procedure *Initialize* must be run when the Data Link Layer begins operation, before any of the processes begin execution. *Initialize* sets certain crucial shared state variables to their initial values. (All other global variables are appropriately reinitialized before each use.) *Initialize* then waits for the channel to be idle, and starts operation of the various processes.

```
procedure Initialize;  
begin  
    frameWaiting := false;  
    deferring := false;  
    newCollision := false;  
    transmitting := false; {In interface to Physical Layer; see below}  
    receiving := false;  
    while carrierSense do nothing;  
    {Start execution of all processes}  
end; {Initialize}
```



### 6.5.2.2 Frame Transmission

The algorithms in this section define data link frame transmission.

The function *TransmitFrame* implements the frame transmission operation provided to the Client Layer:

```

function TransmitFrame (
    destinationParam: AddressValue;
    sourceParam: AddressValue;
    typeParam: typeValue;
    dataParam: DataValue): TransmitStatus;
    procedure TransmitDataEncap; ... {nested procedure; see body below}
begin
    TransmitDataEncap;
    TransmitFrame := TransmitLinkMgmt
end; {TransmitFrame}

```

First, *TransmitFrame* calls the internal procedure *TransmitDataEncap* to construct the frame. It then calls *TransmitLinkMgmt* to perform the actual transmission. The *TransmitStatus* returned indicates the success or failure of the transmission attempt.

*TransmitDataEncap* builds the frame and places the 32-bit CRC in the frame check sequence field:

```

procedure TransmitDataEncap;
begin
    with outgoingFrame do
        begin {assemble frame}
            view := fields;
            destinationField := destinationParam;
            sourceField := sourceParam;
            typeField := typeParam;
            dataField := dataParam;
            fcsField := CRC32(outgoingFrame);
            view := bits
        end {assemble frame}
    end; {TransmitDataEncap}

```

*TransmitLinkMgmt* attempts to transmit the frame, deferring first to any passing traffic. If a collision occurs, transmission is terminated properly and retransmission is scheduled following a suitable backoff interval:

```

function TransmitLinkMgmt: TransmitStatus;
begin
  attempts := 0; transmitSucceeding := false;
  while attempts < attemptLimit and not transmitSucceeding do
    begin {loop}
      if attempts > 0 then BackOff;
      frameWaiting := true;
      while deferring do nothing; {defer to passing frame, if any}
      frameWaiting := false;
      StartTransmit;
      while transmitting do WatchForCollision;
      attempts := attempts + 1
    end; {loop}
    if transmitSucceeding then TransmitLinkMgmt := transmitOK
    else TransmitLinkMgmt := excessiveCollisionError
  end; {TransmitLinkMgmt}

```

Each time a frame transmission attempt is initiated, *StartTransmit* is called to alert the *BitTransmitter* process that bit transmission should begin:

```

procedure StartTransmit;
begin
  currentTransmitBit := 1;
  lastTransmitBit := frameSize;
  transmitSucceeding := true;
  transmitting := true
end; {StartTransmit}

```

Once frame transmission has been initiated, *TransmitLinkMgmt* monitors the channel for contention by repeatedly calling *WatchForCollision*:

```

procedure WatchForCollision;
begin
  if transmitSucceeding and collisionDetect then
    begin
      newCollision := true;
      transmitSucceeding := false
    end
  end; {WatchForCollision}

```

*WatchForCollision*, upon detecting a collision, updates *newCollision* to insure proper jamming by the *BitTransmitter* process.

After transmission of the jam has completed, if *TransmitLinkMgmt* determines that another attempt should be made, *BackOff* is called to schedule the next attempt to retransmit the frame.

```

var maxBackOff: 2..1024; {Working variable of BackOff}

procedure BackOff;
begin
  if attempts = 1 then maxBackOff := 2 else if attempts ≤ backOffLimit
    then maxBackOff := maxBackOff*2;
  Wait(slotTime*Random(0, maxBackOff))
end; {BackOff}

function Random (low, high: integer): integer;
begin
  Random := ...{uniformly distributed random integer r such that low ≤ r <
  high}
end; {Random}

```

*BackOff* performs the truncated binary exponential backoff computation and then waits for the selected multiple of the slot time.

The *Deference* process runs asynchronously to continuously compute the proper value for the variable *deferring*.

```

process Deference;
begin
  cycle {main loop}
  while not carrierSense do nothing; {watch for carrier to appear}
  deferring := true; {delay start of new transmissions}
  while carrierSense do nothing; {wait for carrier to disappear}
  RealTimeDelay(interFrameSpacing);
  deferring := false; {allow new transmissions to proceed}
  while frameWaiting do nothing {allow waiting transmission (if any)}
end {main loop}
end; {Deference}

procedure RealTimeDelay (usec: real);
begin
  {Wait for the specified number of microseconds}
end; {RealTimeDelay}

```

The *BitTransmitter* process runs asynchronously, transmitting bits at a rate determined by the Physical Layer's *TransmitBit* operation:

```

process BitTransmitter;
begin
  cycle {outer loop}
    while transmitting do
      begin {inner loop}
        TransmitBit(outgoingFrame[currentTransmitBit]); {send next bit to
          Physical Layer}
        if newCollision then StartJam else NextBit
      end {inner loop}
    end {outer loop}
end; {BitTransmitter}

procedure NextBit;
begin
  currentTransmitBit := currentTransmitBit + 1;
  transmitting := (currentTransmitBit ≤ lastTransmitBit)
end; {NextBit}

procedure StartJam;
begin
  currentTransmitBit := 1;
  lastTransmitBit := jamSize;
  newCollision := false
end; {StartJam}

```

*BitTransmitter*, upon detecting a new collision, immediately enforces it by calling *StartJam* to initiate the transmission of the jam. The jam may contain 32 to 48 bits of arbitrary data. (*StartJam* uses the first 32 bits of the frame, merely to simplify this program).

### 6.5.2.3 Frame Reception

The algorithms in this section define data link frame reception:

The procedure *ReceiveFrame* implements the frame reception operation provided to the Client Layer:

```

function ReceiveFrame (
    var destinationParam: AddressValue;
    var sourceParam: AddressValue;
    var typeParam: TypeValue;
    var dataParam: DataValue): ReceiveStatus;
function ReceiveDataDecap: ReceiveStatus; ... {nested function; see body
    below}
begin
    repeat
        ReceiveLinkMgmt;
        ReceiveFrame := ReceiveDataDecap;
    until receiveSucceeding
end; {ReceiveFrame}

```

*ReceiveFrame* calls *ReceiveLinkMgmt* to receive the next valid frame, and then calls the internal procedure *ReceiveDataDecap* to return the frame's fields to the Client Layer if the frame's address indicates that it should do so. The returned *ReceiveStatus* indicates the presence or absence of detected transmission errors in the frame.

```

function ReceiveDataDecap: ReceiveStatus;
begin
    receiveSucceeding := RecognizeAddress
        (incomingFrame.destinationField);
    if receiveSucceeding then with incomingFrame do
        begin {disassemble frame}
            view := fields;
            destinationParam := destinationField;
            sourceParam := sourceField;
            typeParam := typeField;
            dataParam := dataField;
            if fcsField = CRC32(incomingFrame) then ReceiveDataDecap := receiveOK
            else if excessBits = 0 then ReceiveDataDecap := frameCheckError
            else ReceiveDataDecap := alignmentError;
            view := bits
        end {disassemble frame}
    end; {ReceiveDataDecap}

```

```

function RecognizeAddress (address: AddressValue): Boolean;
begin
  RecognizeAddress := ... {Returns true for the set of physical, broadcast, and
    multicast-group addresses corresponding to this station}
end; {RecognizeAddress}

```

*ReceiveLinkMgmt* attempts repeatedly to receive the bits of a frame, discarding any fragments from collisions by comparing them to the minimum valid frame size:

```

procedure ReceiveLinkMgmt;
begin
  repeat
    StartReceive;
    while receiving do nothing; {wait for frame to finish arriving}
    excessBits := frameSize mod 8;
    frameSize := frameSize - excessBits; {truncate to octet boundary}
    receiveSucceeding := (frameSize ≥ slotTime); {reject collision fragments}
  until receiveSucceeding
end; {ReceiveLinkMgmt}

procedure StartReceive;
begin
  currentReceiveBit := 1;
  receiving := true
end; {StartReceive}

```

The *BitReceiver* process run asynchronously, receiving bits from the channel at the rate determined by the Physical Layer's *ReceiveBit* operation:

```

process BitReceiver;
  var b: Bit;
begin
  cycle {outer loop}
    while receiving do
      begin {inner loop}
        b := ReceiveBit; {Get next bit from physical link}
        if carrierSense then
          begin{append bit to packet}
            incomingFrame[currentReceiveBit] := b;
            currentReceiveBit := currentReceiveBit + 1
          end; {append bit to packet}
          receiving := carrierSense
        end {inner loop}
      end {outer loop}
end; {BitReceiver}

```

#### 6.5.2.4 Common procedures

The function *CRC32* is used by both the transmit and receive algorithms to generate a 32 bit CRC value:

```
function CRC32 (f: Frame): CRCValue;  
begin  
    CRC32 := {The 32-bit CRC as defined in 6.2.4}  
end; {CRC32}
```

Purely to enhance readability, the following procedure is also defined:

```
procedure nothing; begin end;
```

The idle state of a process (i.e., while waiting for some event) is cast as repeated calls on this procedure.

## 7. ETHERNET PHYSICAL LAYER SPECIFICATION: Baseband Coaxial System

### 7.1 Physical Channel Overview and Model

The Ethernet physical channel (henceforth referred to as the channel) provides the lowest layer in the Ethernet architecture. It performs all the functions needed to transmit and receive data at the physical level, while supporting the Data Link to Physical Layer Interface described in 5.2.

This section describes the requirements for interface and compatibility with a baseband coaxial implementation of the channel.

#### 7.1.1 Channel Goals and Non-goals

This section states the objectives underlying the design of the channel.

##### 7.1.1.1 Goals

The following are the goals of the channel:

1. Provide a means for communication between Ethernet Data Link Entities.
2. Define physical interfaces which can be implemented compatibly among different manufacturers of hardware.
3. Provide all clocks, synchronization, and timing required for both itself and the Ethernet Data Link.
4. Provide high bandwidth and low bit error rates.
5. Provide for ease of installability and serviceability.
6. Provide for high network availability.
7. Support the Ethernet Data Link to Physical Link interface.
8. Low cost.

##### 7.1.1.2 Non-Goals

The following are not goals of the baseband coaxial channel design:

1. Operation at data rates other than 10 megabits per second.
2. Operation with media other than the specified coaxial cable.
3. Simultaneous use of the channel by transmitters using signals not specified in this document.
4. Protection against a malicious user or a malfunctioning Data Link Entity is not provided by the channel as specified. However, higher layers (above the Data Link) and/or physical security means may be employed to achieve this.



### 7.1.2 Characteristics of the Channel

The channel provides (and the data link assumes) the following characteristics:

1. The ability to send and receive information (non-simultaneously) between any two or more data link entities on the same network.
2. The ability to detect the presence of another station's transmission while not transmitting (carrier sense).
3. The ability to detect the presence of another station's transmission while transmitting (collision detect).
4. A total worst-case round trip signal propagation delay (including actual propagation time, synchronization time for all intervening electronics, and signal rise time degradation) of 450 bit times (equal to 45  $\mu$ s for this 10 Mbit channel).

### 7.1.3 Functions Provided by the Channel

The channel hardware provides the following functions in the performance of its role:

1. Means for transmitting and receiving serial bit streams between the data link layer and the media.
2. Generation of clock for synchronization and timing.
3. Means for detecting carrier (non-idle channel).
4. Means for detecting collisions (simultaneous transmission attempts by multiple stations).
5. Coding and decoding of the data link bit stream into a self-synchronizable sequence of electrical signals suitable for transmission on the media provided by the channel.
6. Generation and removal of coding-specific preamble information (a synchronizing header sequence inserted before the first bit of the frame) to ensure that all channel electronics are brought to a known steady-state before the data link frame is transmitted.

### 7.1.4 Implementation of the Channel

The physical channel specification is implementation dependent; most of the channel hardware is fully specified, and little leeway is given to the individual designer. This is done in the interest of compatibility; any system which allows different implementors to use different channel cables, connectors, clock speeds and the like will not be compatible across manufacturer boundaries. Only the design of channel components which are not critical to system compatibility is left to the implementor.

#### 7.1.4.1 General Overview of Channel Hardware

The channel minimally consists of the following functional blocks:

1. The passive broadcast medium (coaxial cable),
2. The transceiver (transmitter-receiver for the coaxial cable),
3. The means for connecting transceivers to a coaxial cable segment and for connecting coaxial cable segments together,
4. The channel clock,
5. The channel data encoder and decoder,
6. The preamble generator and remover,
7. The carrier and collision detect circuits.

The coaxial medium is the only element common to the entire network. A transceiver is required for each station connected to the medium. The transceiver must be located adjacent to the coaxial cable. The latter four components are generally located within, and tightly coupled to, the station hardware implementing the data link function.

It may be useful to be able to physically separate the transceiver from the rest of the channel hardware. This allows topological flexibility, packaging advantages, and improved system availability, as well as allowing for independent manufacture of station hardware and transceivers. To ensure that compatibility is maintained, a physical interface (known as the *transceiver cable*) is identified and specified to connect the transceiver to the station.

Finally, it may be necessary to add *repeaters* to the system, to reach the maximum allowable distance between stations, and to provide additional topological flexibility. Repeaters are implemented using standard transceivers, plus a simple, non-buffered finite state machine.

#### 7.1.4.2 Compatibility Interfaces

There are a number of possibilities for implementing systems or subsystems compatible in whole or in part with this specification. It is important that all implementations be compatible at some point, so that heterogenous systems from different manufacturers' implementations can be interconnected on the same medium. It is not necessary in every case to implement all of the components described herein; e.g., it is possible to design an integrated station/transceiver (without requiring the transceiver cable). The implementor must make the required trade-offs between topological flexibility, system availability, configurability, user needs, and cost when designing the system.

**For a device to be considered compatible, it must meet the applicable requirements at either the transceiver cable or the coaxial cable interface, as appropriate, in addition to the Data Link compatibility required for all stations connected to the network.**

All Ethernets must be compatible at the coaxial cable.

If a transceiver cable is used, it should be the one specified in this document. This allows device manufacturers to build hardware compatible with the Ethernet at the transceiver cable level, without concerning themselves with the details of transceiver implementation. Devices implementing transceiver cable compatibility should be capable of using transceivers designed and built by another manufacturer, on the specified coaxial cable.

Equipment designed for connection to the specified coaxial cable either without a physically separate transceiver or with a non-standard transceiver cable interface will be capable of communication. However, a sacrifice may have been made with respect to interchangeability with other stations.

This scheme of multiple compatibility interfaces allows individual designers some flexibility in making system tradeoffs, yet allows cable manufacturers, transceiver manufacturers and systems manufacturers to use standard commodity parts to produce a compatible communications system.

### 7.1.5 Channel Configuration Model

Certain physical limits have been placed on the physical channel. These revolve mostly around maximum cable lengths (or maximum propagation times), as these affect the slot time as defined in the data link. While the precise specification (in later sections) specify these maxima in terms of propagation times, they were derived from the physical configuration model described here.

The maximum configuration is as follows:

1. A coaxial cable, terminated in its characteristic impedance at each end, constitutes a cable *segment*. A segment may contain a maximum of 500 meters of coaxial cable.
2. A maximum of 2 repeaters in the path between any two stations. Repeaters do not have to be located at the ends of segments, nor is the user limited to one repeater per segment. In fact, repeaters can be used not only to extend the length of the channel, but to extend the topology from one to three-dimensional. Repeaters occupy transceiver positions on each cable segment and count towards the maximum number of transceivers on a segment just as do the logically distinguishable stations.
3. A maximum total coaxial cable length along the longest path between any two transceivers of 1500 meters. The propagation velocity of the coaxial cable is assumed to be 0.77 c worst-case. (c is the velocity of light *in vacuo*; 300,000 kilometers per second.) The total round-trip delay for all the coaxial cable in the system is therefore 13  $\mu$ s worst-case.
4. A maximum of 50 meters of transceiver cable between any station and its associated transceiver. Note that in the worst case the signal must pass through six 50 meter transceiver cables, one at the transmitting station, one at the receiving station, and 2 at each repeater (two repeaters possible). The propagation velocity of the transceiver cable is assumed to be .65 c worst-case. The total round-trip delay for all the transceiver cables is therefore 3.08  $\mu$ s worst-case.
5. A maximum of 1000 meters of point-to-point link anywhere in the system. This will typically be used as a way of linking cable segments in different buildings. Note that a repeater with this internal point-to-point link can be used to repeat signals between segments many hundreds of meters apart. The worst-case propagation velocity of the link cable is assumed to be .65 c; the round-trip propagation delay for 1000 meters is 10.26  $\mu$ s.

Table 7-1 summarizes the allocation of the round-trip propagation delay to the individual components in the channel. Figure 7-1 shows a minimum, typical, and large-scale channel configuration.

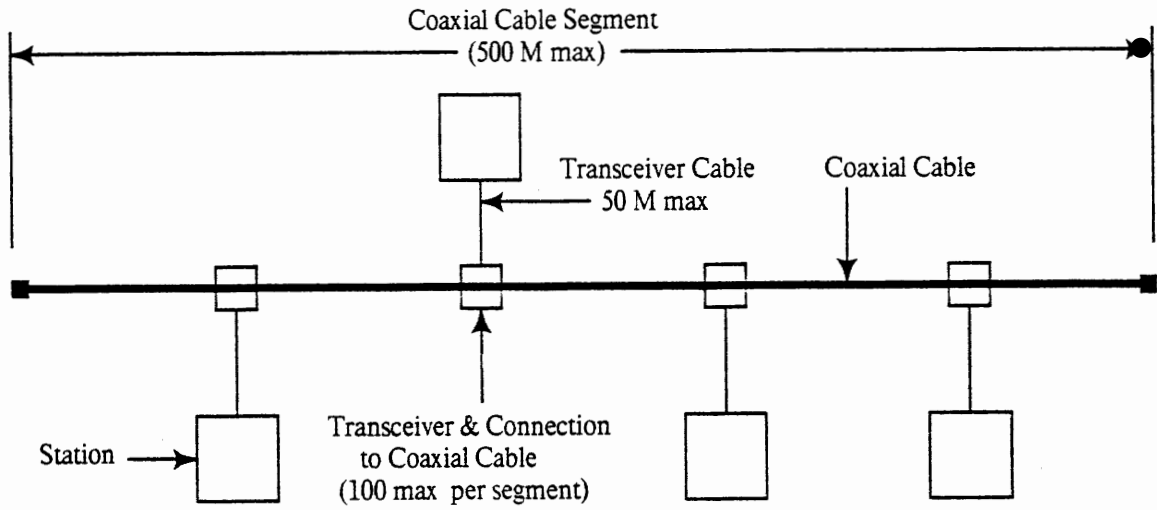

Figure 7-1a: Minimal Configuration

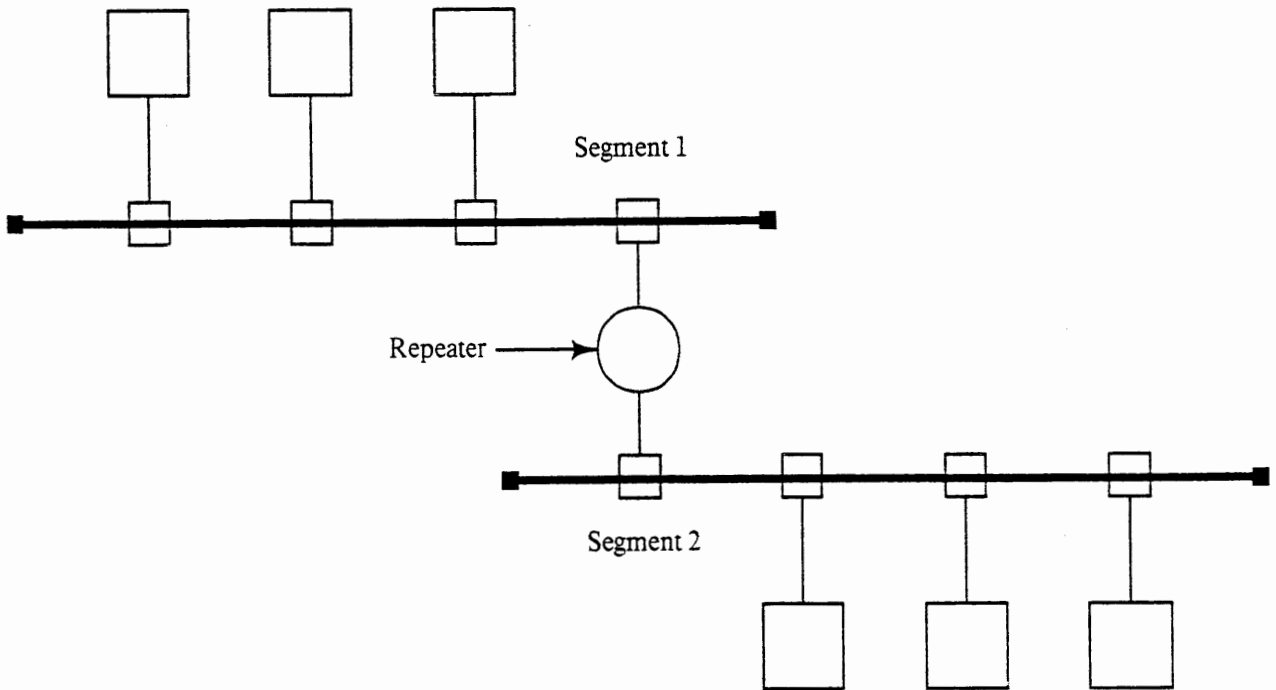

Figure 7-1b: A Typical Medium-scale Configuration

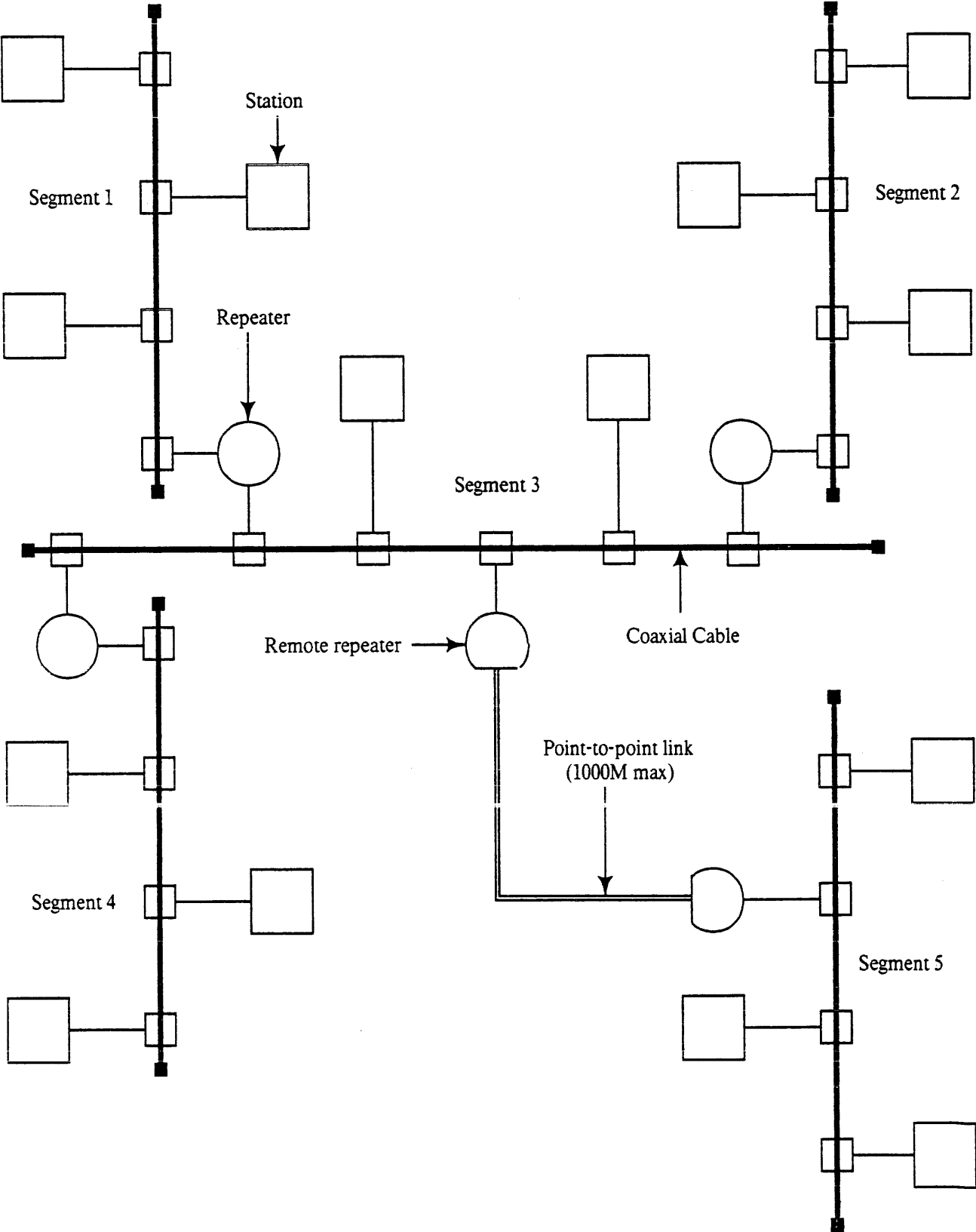

Figure 7-1c: A Typical Large-scale Configuration

Table 7-1: Physical Channel Propagation Delay Budget (Note 1)

Element	Unit Steady-State Delay	Unit Startup Delay	# Units Forward Path (Note 2)	# Units Return Path	Total Delay
Encoder	0.1 $\mu$ S	0	3	3	0.60 $\mu$ S
Transceiver Cable	5.13 nS/M	0	300 M	300 M	3.08 $\mu$ S
Transceiver (transmit path)	0.50 $\mu$ S	0.2 $\mu$ S	3	3	1.50 $\mu$ S
Transceiver (receive path)	0.50 $\mu$ S	0.5 $\mu$ S	3	0	1.65 $\mu$ S
Transceiver (collision path)	0	0.5 $\mu$ S	0	3	1.50 $\mu$ S
Coaxial Cable	4.33 nS/M	0	1500 M	1500 M	13.00 $\mu$ S
Point-to-Point Link Cable	5.13 nS/M	0	1000 M	1000 M	10.26 $\mu$ S
Repeater (repeat path)	0.8 $\mu$ S	0	2	0	1.60 $\mu$ S
Repeater (collision path)	0.2 $\mu$ S	0	0	2	0.40 $\mu$ S
Decoder	0.1 $\mu$ S	0.8 $\mu$ S	2	0	1.80 $\mu$ S
Carrier Sense	0	0.2 $\mu$ S	3	0	0.60 $\mu$ S
Collision Detect	0	0.2 $\mu$ S	0	3	0.60 $\mu$ S
Signal Rise Time (to 70% in 500 M) (Note 3)	0	0.1 $\mu$ S	3	0	0.30 $\mu$ S
Signal Rise Time (50% to 94% in 500 M) (Note 4)	0	2.7 $\mu$ S	0	3	8.10 $\mu$ S
Total Worst-Case Round-Trip Delay					44.99 $\mu$ S

Note 1: All quantities given are worst-case (both number of units and unit delays per unit).

Note 2: The propagation delay has been separated into "forward-path" and "return path" delay. This is because in one direction it is carrier sense which is being propagated through the channel, and in the return direction it is collision detect which is being propagated. The two signals have different propagation delays.

Note 3: In the worst-case, the propagated signal must reach 70% of its final value to be detected as valid carrier at the end of 500 meters of coaxial cable. This rise time must be included in the propagation delay budget.

Note 4: In the worst-case the propagated collision on the return path must reach 94% of its final value to be detected as a collision at the end of 500 meters of coaxial cable.

### 7.1.6 Channel Interfaces

The channel specification hinges around three well-defined entities; the transceiver and coaxial cables (shown as compatibility interfaces in Figure 4-1), and the logical interface between the physical channel and the data link controller (shown in Figure 4-4). Note that the former two are physical interfaces specific to the channel, and are specified in the interest of compatibility. The latter is provided as a means by which the data link controller can interact with the physical channel.

The channel access component of the logical interface (discussed in 4.4.1) comprises the collision and carrier detect functions described in 7.5.2 and 7.5.3, as well as the actual transmission of signals on the media. The data encoding and decoding functions described in 4.4.1 comprise the generation and decomposition of encoded signals suitable for transmission (described in 7.5.1), the generation and removal of code-specific preamble (described in 7.5.1.3 and 7.5.4.1), and the serial bit stream interface between the layers.

Section 5 describes the interface between the data link and physical layers as a series of Pascal procedures, functions, and shared variables. The data link specification in section 6 shows how the data link uses this interface to communicate between client layers. However, this specification will not attempt to model the operation of the physical channel in Pascal. The interface between layers is supported by the physical hardware which provides the ability to send and receive bit streams, provide timing, and signal carrier sense and collision detect to the data link.

The remainder of this section specifies the requirements for compatibility at both the transceiver cable and the coaxial cable. In addition, the specifications for the transceiver, which interfaces the transceiver cable to the coaxial cable is given, as well as the specification for the logic required between the transceiver cable and the interface to the data link.

## 7.2 Transceiver Cable Compatibility Interface Specifications

The transceiver cable is the means by which a physically separate transceiver is connected to a station. It provides one of the compatibility interfaces described in 7.1.4.2.

### 7.2.1 Transceiver Cable Signals

The transceiver cable carries four signals: Transmit, Receive, Collision Presence, and Power. Each signal is carried on a twisted pair of conductors in the cable.

#### 7.2.1.1 Transmit Signal

The transmit pair carries encoded data for which the data link is requesting transmission on the channel. This signal is generated by the data encoder, with the transceiver cable drive characteristics specified in 7.2.4.



### 7.2.1.2 Receive Signal

The receive pair carries encoded data from the transceiver to the station. It typically goes to the data decoder and the carrier sense circuitry. In the steady-state, all transitions and lack of transitions on the coaxial cable become transitions and lack of transitions on the receive pair, with the transceiver cable drive characteristics specified in 7.2.4. (During start-up, the first few bits may be absorbed by the transceiver to attain steady-state.)

In the case of a station transmitting without collision interference, the station's own transmit transitions on the coaxial cable will also appear on the receive pair, after a delay due to propagation through the transceiver. During collisions (whether or not that transceiver is involved in the collision) transitions on the receive lead are undefined; they may or may not meet decoder phase requirements, or they may not be present at all for extended periods. Thus the receive signal on the transceiver cable cannot be used alone to deterministically generate the carrier sense signal. This is described in more detail in 7.5.3.

### 7.2.1.3 Collision Presence Signal

The collision presence pair is used by the transceiver to indicate the presence of multiple transmission attempts on the coaxial cable. This is done by transmitting a square wave with a 10MHz fundamental frequency through the standard transceiver cable driver (described in 7.2.4). An oscillator is used instead of a simple level shift to allow AC coupling at the transceiver. Transceivers use the collision presence signal to indicate one of two conditions: the transceiver is transmitting and there is an attempt by another station to transmit at the same time, or there is a simultaneous transmission attempt by three or more stations regardless of whether the transceiver in question is transmitting.

### 7.2.1.4 Power

A pair of wires is designated for providing power to the transceiver. When the transceiver cable is implemented, the station end of the cable must supply a voltage between +12 and +15 Vdc  $\pm$  5% with at least 0.5 Amperes available to the cable for remotely powering the transceiver. The power source must meet applicable requirements for UL Class 2 wiring devices.

## 7.2.2 Transceiver Cable Parameters

### 7.2.2.1 Mechanical Configuration

The transceiver cable consists of four stranded, twisted pair conductors, plus an overall shield and insulating jacket. The conductor and jacket insulating material may be polyethylene or other suitable material. The flammability characteristics of the insulating material must be suitable for the installed environment.

### 7.2.2.2 Characteristic Impedance

The differential mode characteristic impedance of all pairs shall be  $78 \Omega$ ,  $\pm 5 \Omega$ , in the configuration.

### 7.2.2.3 Attenuation

The signal attenuation of any pair shall not exceed 3 dB (measured at 10 MHz) for the total length between the transceiver and the station.

### 7.2.2.4 Velocity of Propagation

The minimum velocity of propagation of the transceiver cable shall be 0.65 c.

### 7.2.2.5 Pulse Distortion

Pulse distortion shall not exceed  $\pm 1$  nS at the end of 50 meters of cable when driven with random 10 Mbit data encoded in accordance with 7.5.1.

### 7.2.2.6 Resistance

The resistance of the conductors used for the power pair shall not exceed 40 milliohms per meter.

### 7.2.2.7 Transfer Impedance

The common mode transfer impedance of the transceiver cable shall not exceed the values shown in Figure 7-2 as a function of frequency. The differential mode transfer impedance of the cable with respect to any pair shall be 20 dB lower than the specified common mode transfer impedance.

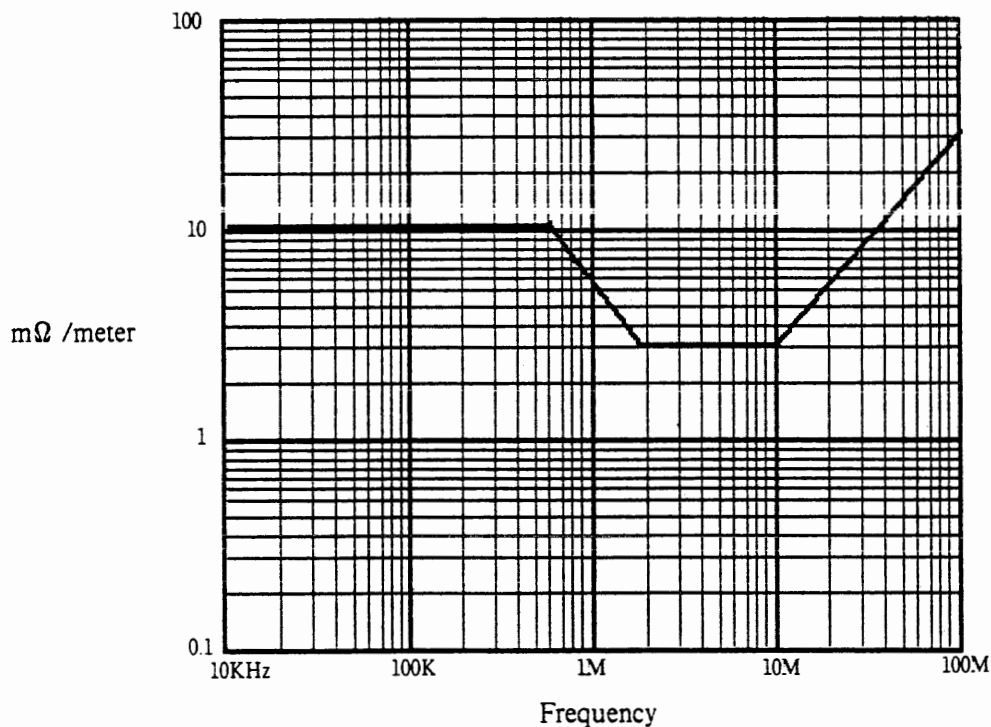

Figure 7-2: Transceiver Cable Transfer Impedance

### 7.2.3 Transceiver Cable Connectors

The connectors used at the ends of the transceiver cable shall be 15 conductor 'D' subminiature types (Cinch type DASM-15 or equivalent). The end of the cable that mates with the transceiver must use a female connector with a slide lock assembly (Cinch type DA 51220-1 or equivalent). The transceiver must provide a mating male connector with locking posts. The other end of the transceiver cable (which mates with a female connector at the station) must use a male connector with locking posts (Cinch type D 53018 or equivalent). The station must provide a female connector with the slide lock assembly.

Because of the end-to-end matching of the connectors, transceiver cables may be extended by concatenating transceiver cable sections. (The transceiver cable sections function as 'extension cords'.) A cable with multiple sections must still meet the cable loss characteristics of 7.3.1.1.2.

The pin assignment is given in the following table:

#### Transceiver Cable Connector Pin Assignment

1. Shield (See note)	
2. Collision Presence +	9. Collision Presence -
3. Transmit +	10. Transmit -
4. Reserved	11. Reserved
5. Receive +	12. Receive -
6. Power return	13. Power
7. Reserved	14. Reserved
8. Reserved	15. Reserved

Note: Shield must be terminated to connector shell as well as pin 1.

Metal, metallized plastic, or otherwise shielded connector backshells must be used to ensure shield integrity.

### 7.2.4 Transceiver Cable Drive

This section describes the requirements for driving any of the signal pairs in the transceiver cable: transmit, receive, and collision presence.

The AC signal levels presented to the transceiver cable shall be  $\pm 700$  mV nominal, balanced differential drive into  $78 \pm 5 \Omega$ . The common mode voltage presented to the transceiver cable shall not exceed that allowed at the receiver, as specified in 7.2.5.2. Signal waveform shall be as shown in Figure 7-3.

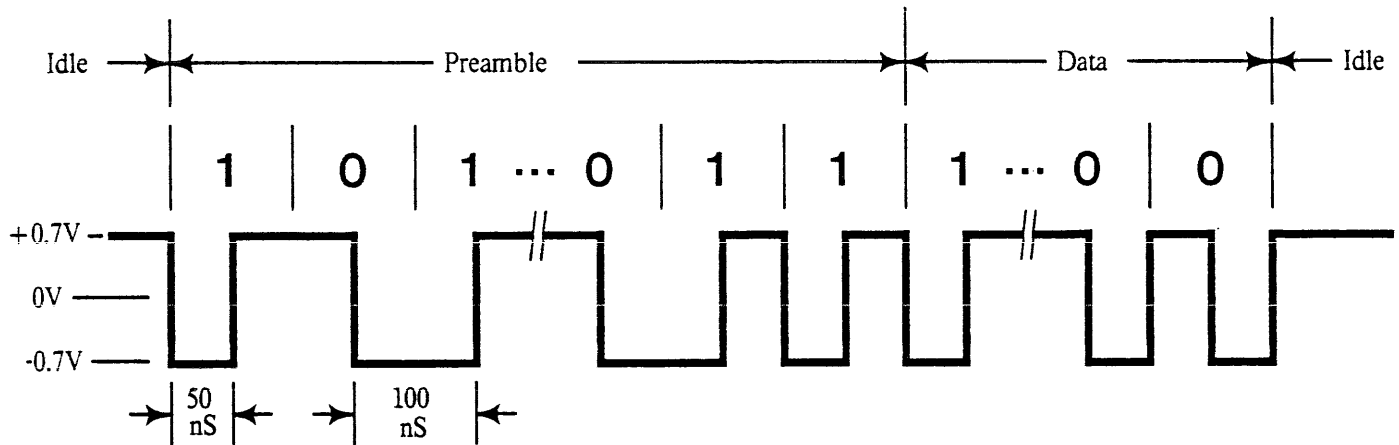

1. Voltages are measured differentially at output of transceiver cable driver.
2. Rise and fall times meet 10,000 series ECL requirements.

Figure 7-3: Typical Transceiver Cable Waveform

The transceiver cable driver must be capable of maintaining the specified minimum differential signal into the worst case low cable impedance ( $73 \Omega$  differential,  $18.5 \Omega$  common mode) in the environment specified in section 7-7.

The idle state of the output shall be high (+ 700 mV nominal); the first transition presented is negative-going, the last transition must be positive-going. Note that the presence of AC coupling may cause the voltage as specified at the output of the transceiver cable drive circuit not to appear on the transceiver cable in the idle state.

A typical transceiver cable drive circuit is given in Appendix D.

### 7.2.5 Transceiver Cable Receive

The following sections specify the requirements for receiving signals from any signal pair in the transceiver cable: transmit, receive, and collision presence. The circuit must be capable of receiving the signals from the transceiver cable driver specified in 7.2.4 through the cable specified in 7.2.2 in the worst case. A typical receive circuit is given in Appendix D.

#### 7.2.5.1 Load Impedance and Termination

The termination impedance shall be  $78 \Omega \pm 1\%$  differential mode, and  $18.5 \Omega$  minimum common-mode, over the frequency range of 3-20 MHz.

#### 7.2.5.2 Common Mode and CMRR

The common mode range and the common mode rejection ratio shall be sufficient to maintain a 5:1 signal to noise ratio in the environment specified in 7.7, measured at the input to the transceiver cable receiver. The common mode DC voltage at the input of the receiver shall be in the range of zero to +5 Vdc..

### 7.3 Coaxial Cable Compatibility Interface Specifications

The coaxial cable is the common, shared broadcast medium through which stations communicate. It provides one of the compatibility interface points described in 7.1.4.2.

#### 7.3.1 Coaxial Cable Component Specifications

The cable is of constant impedance, coaxial construction. It is terminated at each end by a *terminator* (specified in 7.3.1.3), and connection provided for each transceiver. Coaxial cable connectors are used to make the connection from the cable to the terminators, and between cable sections (if needed). The cable has various electrical and mechanical requirements which must be met to ensure proper operation.

##### 7.3.1.1 Coaxial Cable Parameters

###### 7.3.1.1.1 Characteristic Impedance

The average characteristic impedance of the cable shall be  $50 \pm 2 \Omega$ , measured according to Mil. Std. C17-E. Periodic variations in impedance along a single piece of cable may be up to  $\pm 3 \Omega$  sinusoidal, centered around the average value, with a period  $< 2$  meters. Note that the proper operation of the network is dependent upon the cable characteristic impedance; its value and tolerance are critical.

###### 7.3.1.1.2 Attenuation

The attenuation of a cable segment shall not exceed 8.5 dB measured at 10 MHz, nor 6.0 dB measured at 5 MHz.

###### 7.3.1.1.3 Velocity of Propagation

The minimum acceptable velocity of propagation is 0.77 c..

#### 7.3.1.1.4 Mechanical Requirements

The cable used should be suitable for routing in various environments, including but not limited to, dropped ceilings, raised floors, and cable troughs. The jacket must provide insulation between the cable sheath and any building structural metal. Also, the cable must be capable of accepting coaxial cable connectors, described in 7.3.1.2. The cable must in addition conform to the following requirements:

1. The center conductor must be 0.0855"  $\pm$  .0005" diameter solid, tinned copper,
2. The core dielectric material must be foamed,
3. The inside diameter of the innermost shield must be .242" minimum,
4. The outside diameter of the outermost shield must be .326"  $\pm$  .007",
5. The outermost shield must be greater than 90% coverage tinned copper braid,
6. The jacket O.D. must be 0.405" nominal,
7. The cable concentricity must be 90% minimum.

The cable must also meet applicable flammability criteria and local codes for the installed environment. Different (e.g., polyethylene and Teflon dielectric) types of cable sections may be interconnected, while meeting the sectioning requirements of 7.6.1.

#### 7.3.1.1.5 Pulse Distortion

Pulse distortion shall not exceed  $\pm 7$  nS at the end of 500 meters of cable when driven with random 10 Mbit data encoded in accordance with 7.5.1.

#### 7.3.1.1.6 Jacket Marking

The cable jacket must be marked with annular rings in a color contrasting with the background color of the jacket. The rings must be spaced at 2.5 meter  $\pm$  5 cm regularly along the entire length of the cable. It is permissible for the 2.5 meter spacing to be interrupted at discontinuities between cable sections joined by connectors. (See 7.6.2 for transceiver placement rules which mandate cable markings.)

#### 7.3.1.1.7 Transfer Impedance

The transfer impedance of the cable shall not exceed the values shown in Figure 7-4 as a function of frequency.

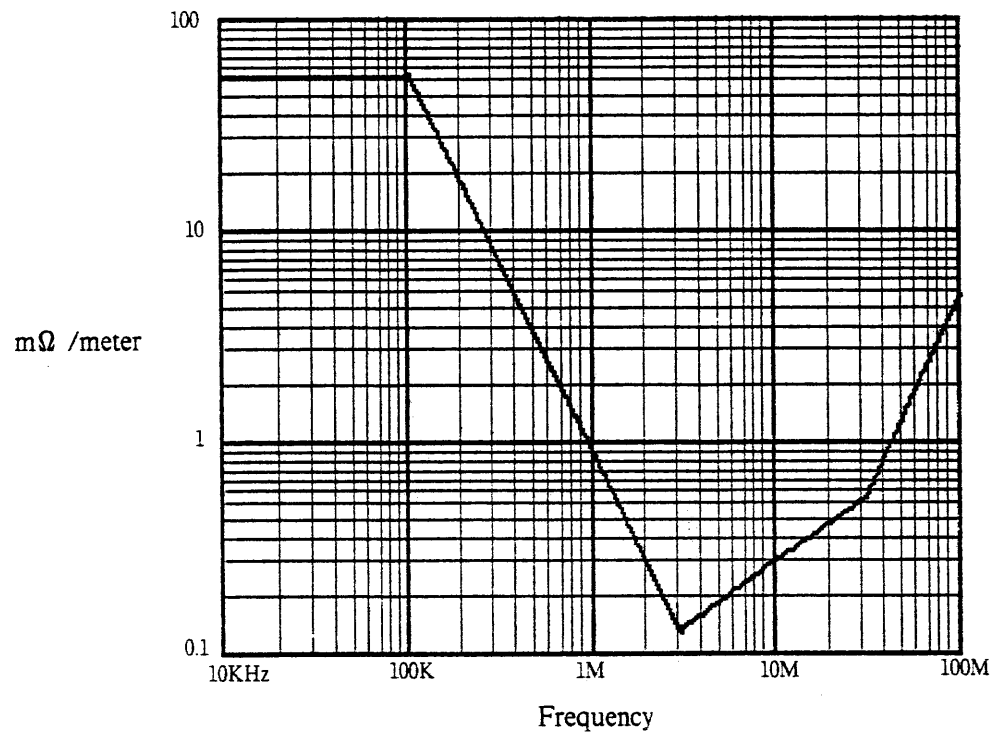

Figure 7-4: Maximum Coaxial Cable Transfer Impedance

### 7.3.1.2 Coaxial Cable Connectors

Coaxial cable connectors are used to join cable sections and attach terminators. Three types of connectors may be necessary; male plugs, female jacks, and female-to-female barrels. Plugs are used exclusively at the ends of all cable sections. Jacks are used to house cable terminators. Barrels are used to join cable sections.

All connectors are N series,  $50 \Omega$  constant impedance types. Since the frequencies present in the transmitted data are well below UHF range (being band-limited to approximately 20 MHz), military versions of the connectors are not required (but are acceptable).

Means must be provided to ensure that the connector shell (which connects to the cable sheath) does not make contact with any building metal, or other unintended conductor. A sleeve or boot to be slid over the connector at installation time is suitable.

### 7.3.1.3 Coaxial Cable Terminators

Coaxial cable terminators are used to provide a termination impedance for the cable equal in value to its characteristic impedance, thereby eliminating any reflection from the ends of the cables. Terminators shall be packaged within an inline female jack connector. The termination impedance shall be  $50 \Omega \pm 1\%$  measured from 0-50 MHz, with the magnitude of the phase angle of the impedance not to exceed 5 degrees. The terminator power rating shall be 1 watt or greater.

#### 7.3.1.4 Transceiver-to-Coaxial Cable Connections

A means must be provided to allow for attaching a transceiver to the coaxial cable. The connection must disturb the transmission line characteristics of the cable as little as possible; it must present a predictably low shunt capacitance, and therefore a negligibly short stub length. For this reason, the transceiver must be located as close to its cable connection as possible; they are normally considered to be one assembly. Long (greater than 3 cm) connections between the coaxial cable and the input of the transceiver are not acceptable.

The transceiver-to-coaxial cable connection shall present less than 2 picofarads shunt capacitance to the coaxial cable, not including any transceiver electronics. If the design of the connection is such that the coaxial cable must be severed to install the transceiver, the coaxial cable segment must still meet the sectioning requirements of 7.6.1. Any coaxial connectors used on a severed cable must be type N, as specified in 7.3.1.2.

#### 7.3.2 Coaxial Cable Signaling

The AC component of the signal on the coaxial cable due to a single transceiver as measured on the coaxial cable immediately adjacent to the transceiver connection shall be  $\pm 16$  mA nominal (14 mA min, 19 mA max). The DC component shall be one-half the AC component, plus 4.5 mA (4 mA min, 5 mA max). The actual current measured at a given point on the cable is a function of the transmitted current and the cable loss to the point of measurement. Positive current is defined as current out of the center conductor of the cable (into the transceiver). Cable loss is specified in 7.3.1.1.2.

The 10%-90% rise and fall times shall be  $25 \pm 5$  nsec. Figure 7-5 shows typical waveforms present on the cable. Harmonic content generated from a 10 MHz fundamental periodic input shall meet the following requirements:

Second and Third Harmonics:	-20 dB min
Fourth and Fifth Harmonics:	-30 dB min
Sixth and Seventh Harmonics:	-40 dB min
All Higher Harmonics:	-50 dB min

The signals as generated from the encoder (described in 7.5.1.1) shall appear on the coaxial cable without any inversions.



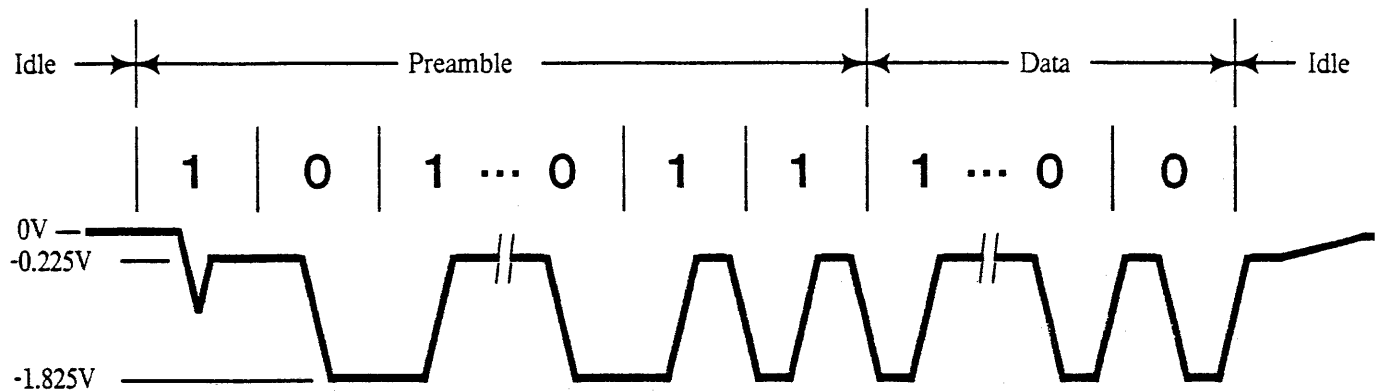

1. Voltages given are nominal; worst case is given in text.
2. Rise time is 25 nS nominal.
3. Voltages are measured on coaxial cable adjacent to transceiver.

Figure 7-5: Typical Coaxial Cable Waveform

## 7.4 Transceiver Specifications

The following sections specify the requirements for a transceiver.

### 7.4.1 Transceiver-to-Coaxial Cable Interface

The following sections describe the interface between the transceiver and the coaxial cable. Positive current is defined as current into the transceiver (out of the center conductor of the cable).

#### 7.4.1.1 Input Impedance

The shunt capacitance presented to the coaxial cable by the transceiver circuitry (not including the means of attachment to the coaxial cable) shall not exceed 2 picofarads. The shunt resistance presented to the coaxial cable shall be greater than 50 K $\Omega$ .

These conditions must be met in both the power off and the power on, not transmitting states.

#### 7.4.1.2 Bias Current

The transceiver must draw between -2 and +50  $\mu$ A in the power-off and the power-on, not transmitting states.

### 7.4.1.3 Transmit Output Levels

Signals received from the transceiver cable transmit pair must be transmitted onto the coaxial cable with the characteristics specified in 7.3.2. Note that 7.3.2 specifies the current level on the coaxial cable. Since the coaxial cable proceeds in two directions away from the transceiver, the current into the transceiver is actually twice the current measured on the coaxial cable.

Transmitted output asymmetry shall not exceed 2 ns for a 50/50 duty cycle input on the transceiver cable transmit pair.

## 7.4.2 Transceiver-to-Transceiver Cable Interface

### 7.4.2.1 Transmit Pair

The transceiver must present the transceiver cable receive characteristics specified in 7.2.5 to the transmit pair. At the start of a frame transmission, no more than 2 bits (two 100 ns bit cells) of information may be received from the transmit pair and not transmitted onto the coaxial cable. The steady-state propagation delay between the transmit pair input and the coaxial cable output shall not exceed 50 ns. There are no signal inversion between the transceiver cable transmit pair and the coaxial cable.

### 7.4.2.2 Receive Pair

The transceiver must present the transceiver cable transmit characteristics specified in 7.2.4 to the receive pair. Asymmetry as seen on the receive pair shall not exceed  $\pm 2$  nsec for a  $\pm 200$  mV peak sinusoidal input from the coaxial cable.

The signal from the coaxial cable shall pass through AC coupling with an appropriate time constant before proceeding to the receive pair. The time constant should compensate for the coaxial cable pulse distortion.

At the start of a frame reception from the coaxial cable, no more than 5 bits (five 100 ns bit cells) of information may be received from the coaxial cable and not transmitted onto the receive pair. In addition, it is permissible for the first bit sent over the receive pair to contain encoding phase violations or invalid data, however all successive bits of the frame shall be valid and meet encoding rules. The steady-state propagation delay between the coaxial cable and the receive pair output shall not exceed 50 ns. There are no signal inversions between the coaxial cable and the transceiver cable receive pair.

### 7.4.2.3 Collision Presence Pair

The transceiver must present the transmitter characteristics specified in 7.2.4 to the collision presence pair. The signal presented to the collision presence pair shall be a periodic waveform with a  $10 \text{ MHz} \pm 15\%$  frequency. This signal shall be presented to the collision presence pair no more than 5 bit times (500 nS) after the average signal on the coaxial cable at the transceiver exceeds either that which could be produced by two transceiver outputs in the worst case (if the transceiver in question is not transmitting), or that which could be produced by that transceiver alone in the worst case (if that transceiver is transmitting).

### 7.4.2.4 Power Pair

The transceiver cable provides power which may be used for operation of the transceiver electronics. The power available shall be as described in 7.2.1.4. The distribution impedance of the transceiver cable is  $4 \Omega$  maximum, for a 50 meter cable with the resistance specified in 7.2.2.6. In order for the transceiver to derive its operating power from the power pair, circuitry must be employed to provide the required electrical isolation specified in 7.4.3.

### 7.4.3 Electrical Isolation

The transceiver must provide electrical isolation between the transceiver cable and the coaxial cable. The isolation impedance shall be greater than  $250 \text{ K}\Omega$ , measured between any conductor (including shield) of the transceiver cable and either the center conductor or shield of the coaxial cable, at 60 Hz. The breakdown voltage of the isolation means provided shall be at least 250 VAC, rms.

### 7.4.4 Reliability

No single nor double component failure within the transceiver electronics shall impede communication among other transceivers on the coaxial cable. Connectors and other passive components comprising the means of connecting the transceiver to the coaxial cable shall be designed to minimize the probability of total network failure.

## 7.5 Channel Logic

The following sections describe the functions that must be performed to properly interface between the data link and the transceiver cable. They are normally implemented as logic, typically within the same device implementing the data link layer.

### 7.5.1 Channel Encoding

The channel shall use Manchester phase encoding, with a data rate of 10 Mbps,  $\pm .01\%$ , measured at the encoder clock. Thus, each bit cell is 100 ns long.

The following section describes the requirements for encoding and decoding signals to be transmitted on, or received from the coaxial or transceiver cables.

### 7.5.1.1 Encoder

The encoder is used to translate physically separate signals of clock (synchronization) and data into a single, self-synchronizable serial bit stream, suitable for transmission on the coaxial cable by the transceiver.

During the first half of the bit cell time, the serial signal transmitted is the logical complement of the bit value being encoded during that cell. During the second half of the bit cell time, the uncomplemented value of the bit being encoded is transmitted. Therefore, there is always a signal transition (either positive-going or negative-going, depending on the bit being encoded) in the center of each bit cell. A timing diagram for a typical bit stream is given in Figure 7-6.

The encoder output drives the transmit pair of the transceiver cable, and ultimately, the coaxial cable through the transceiver. The encoder output asymmetry must not exceed 0.5 ns. The encoder shall provide the defined output for the first (and all subsequent) bits presented to its input. All information submitted for encoding shall appear at the output of the encoder.

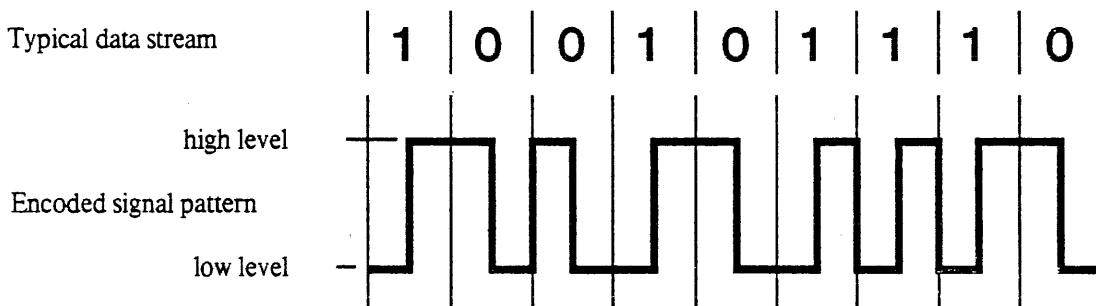

Figure 7-6: Manchester Encoding

### 7.5.1.2 Decoder

The decoder is used to separate the incoming phase encoded bit stream into a data stream and a clock signal. The decoder must be able to provide data and clock signals usable by the data link under the asymmetry imposed by the worst case system configuration. The decoder must provide usable output (clock and data) after no more than 8 bit cell times after reception of an encoded signal. The first signals received from the transceiver at the beginning of frame reception may not constitute a valid, properly encoded bit; it is possible for the time from the first transition seen to the first true mid-bit cell transition to assume any value from zero to 100 ns.

The decoder input is normally derived from the coaxial cable, through the transceiver cable receive pair. It is not necessary for the decoder to provide usable output when there is a collision on the coaxial cable, regardless of whether the station using that decoder is involved in the collision.

### 7.5.1.3 Preamble Generation

Because most of the channel circuitry is allowed to provide valid output some number of bit times after being presented valid input, it is necessary for a preamble to be sent before the start of data link information, to allow the channel circuitry to reach its steady-state, with valid outputs throughout the system. Upon request by the data link to transmit the first bit of a new frame, the channel shall first transmit the preamble; a predetermined bit sequence used for channel stabilization and synchronization. If, while transmitting the preamble, the channel logic asserts the collision detect signal as specified in 7.5.2, any remaining preamble bits shall not be sent. The channel should immediately proceed with the transmission of the bit submitted by the data link.

The preamble is a 64 bit pattern to be presented to the channel encoder in the same manner as data link information. The pattern is:

10101010 10101010 10101010 10101010 10101010 10101010 10101010 10101011.

The bits are transmitted in order, from left to right. The nature of the pattern is such that when encoded, it appears as a periodic waveform on the cable, with a 5 MHz frequency. Excepting the final two bits, the only transitions present in the waveform are in the center of the bit cells. This is depicted in Figure 7-7. The last two bits of the preamble contain transitions at both the bit cell centers and the edges, and are used to indicate the end of the preamble, and the beginning of the data link encapsulation portion of the frame. The next bit transmitted is the bit originally submitted by transmission by the data link.

Preamble removal on reception is discussed in 7.5.4.1.

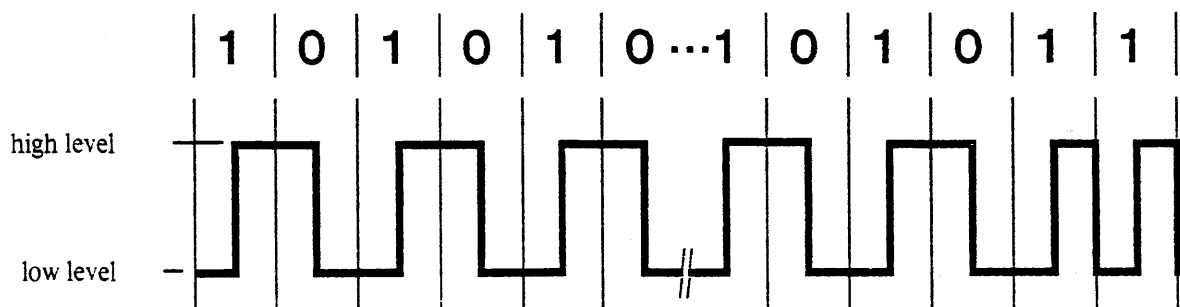

Figure 7-7: Preamble Encoding

### 7.5.2 Collision Detect Signal

The channel must indicate to the data link when the signals on the coaxial cable imply simultaneous transmission attempts by more than one station. This is normally indicated through the collision presence pair in the transceiver cable, described in 7.2.1.3.

The channel logic must assert the collision detect signal within 2 bit times (200 ns), following the onset of collision presence. This collision detect signal shall be asserted only when the data link is transmitting. A functional logic description of the collision detect signal is shown in Figure 7-8.

Following the loss of collision presence information, the channel must deassert the collision detect signal within 1.6 bit cell times (160 ns).

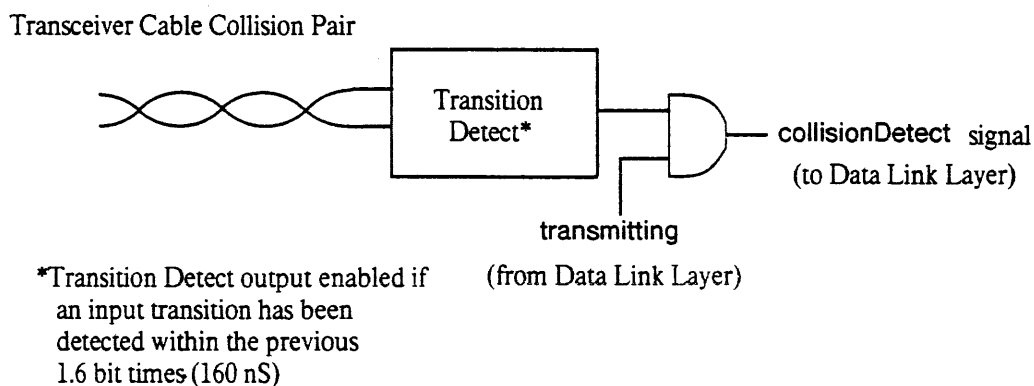

Figure 7-8: Functional Logic of collisionDetect Signal

### 7.5.3 Carrier Sense Signal

The channel must indicate to the data link the presence of carrier, a signal transmission attempt on the coaxial cable by a station. This is normally indicated through both the receive and collision presence pairs in the transceiver cable, described in 7.2.1.

The carrier sense signal shall be asserted when one or more station is attempting transmission on the cable, regardless of whether the station sensing carrier is transmitting at that time. The channel logic must assert the carrier sense signal within 2 bit times (200 ns) following the onset of carrier presence information. A

functional logic description of these signals is shown in Figure 7-9.

Following the loss of carrier presence information (receive transitions and collision presence information) the channel must deassert the carrier sense signal within 1.6 bit cell times (160 ns).

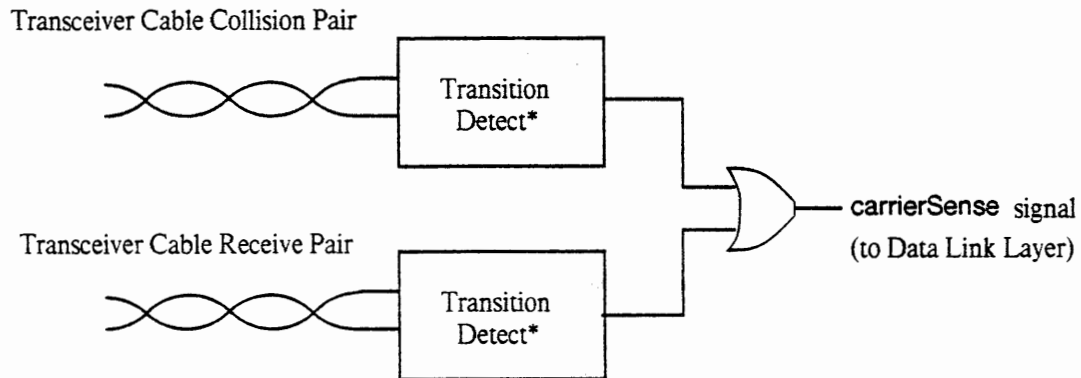

\*Transition Detect output enabled if an input transition has been detected within the previous 1.6 bit times (160 nS)

Figure 7-9: Functional Logic of carrierSense Signal

## 7.5.4 Channel Framing

During reception, the channel must provide the data link with signals to indicate beginning and end of frame.

### 7.5.4.1 Beginning-of-Frame Sequence

The channel logic recognizes the presence of activity on the medium through the carrier sense signal. This is the first indication that the frame reception process should begin. However, dependent upon the physical configuration of the system, there are some number of preamble bits to be received by the channel before the start of the data link frame as indicated by the double-1 at the end of preamble. In addition, the first signals received from the decoder may be invalid due to the first bit allowance of the transceiver (see 7.4.2.2). The channel must wait no less than 8 bit times (800 nS) before monitoring the output of the decoder for the 'double-1' indicating end of preamble, and beginning of data link frame. Upon reception of the double-1, the channel shall begin passing successive bits to the data link through the defined receive bit stream interface. If, after waiting the required 8 bit times, a 'double-0' is encountered, the physical channel shall not pass any bits of

the current frame to the data link. Normal operation of the data link and channel shall resume on the subsequent frame.

#### 7.5.4.2 End-of-Frame Sequence

As specified in 7.5.3, the carrier sense signal must be deasserted no later than 1.6 bit times (160 ns) after the cessation of activity on the coaxial cable as seen by the channel logic. The channel ensures that no extraneous bits will appear at the end of a frame following the last valid bit.

### 7.6 Channel Configuration Requirements

#### 7.6.1 Cable Sectioning

The 500 meter maximum length coaxial cable segment need not be made from a single, homogeneous length of cable. The boundary between two cable sections (joined by coaxial connectors; two male plugs and a barrel) represents a signal reflection point due to the impedance discontinuity caused by the batch-to-batch impedance tolerance of the cable. Since the worst-case variation from 50  $\Omega$  is 2  $\Omega$  (see 7.3.1.1.1), a possible worst-case reflection of 4% may result from the joining of two cable sections. The configuration of long cable segments (up to 500 meters) from smaller sections must be made with care. The following recommendations apply, and are given in order of preference:

1. If possible, the total segment should be made from one homogeneous (no breaks) cable. This is feasible for short segments, and results in minimal reflections from cable impedance discontinuities.
2. If cable segments must be built up from smaller sections, it is highly desirable to ensure that all the sections are from the same manufacturer and lot. This is equivalent to using a single cable, since the cable discontinuities are due to extruder limitations, and not extruder-to-extruder tolerances. There are no restrictions in cable sectioning if this method is used. However, if a cable section in such a system is later replaced, it must be replaced either with another cable from the same manufacturer and lot, or with one of the standard lengths described below.
3. If uncontrolled cable sections must be used in building up a longer segment, the lengths should be chosen such that reflections, when they occur, do not have a high probability of adding in phase. This can be accomplished by using lengths which are odd integral multiples of a half-wavelength in the cable at 5 MHz; this corresponds to using lengths of 23.4, 70.2, and 117 meters ( $\pm 0.5$  meters) for all sections. These are considered to be the standard lengths for all cable sections. Using these lengths exclusively, any mix or match of cable sections may be used to build up a 500 meter segment without incurring excessive reflections.



4. As a last resort, an arbitrary configuration of cable sections may be employed, if it has been confirmed by analysis or measurement that the worst-case signal reflection due to the impedance discontinuities at any point on the cable does not exceed 7% of the incident wave when driven by a transceiver meeting the specifications of 7.4.

### 7.6.2 Transceiver Placement

Transceivers and their associated connections to the cable cause signal reflections due to their non-infinite bridging impedance. While this impedance must be implemented as specified in 7.3.1.4 and 7.4.1, the placement of transceivers along the coaxial cable must also be controlled to insure that reflections from transceiver do not add in phase to a significant degree.

Coaxial cables marked as specified in 7.3.1.1.6 have marks at regular 2.5 meters spacing; a transceiver may be placed at any mark on the cable. This guarantees both a minimum spacing between transceivers of 2.5 meters, as well as controlling the relative spacing of transceivers to insure non-alignment on fractional wavelength boundaries.

The total number of transceivers on a cable segment shall not exceed 100.

### 7.6.3 System Grounding

The sheath conductor of the coaxial cable shall not make electrical contact with any earth reference, building structural metal, ducting, plumbing fixture, or other unintentioned conductor. Insulators may be used to cover any coaxial connectors used to join cable sections and terminators, to insure that this requirement is met. A sleeve or boot attached at installation time is acceptable.

The sheath conductor of the transceiver cable shall be connected to the earth reference or chassis of the device housing the station logic.

## 7.6.4 Repeaters

Repeaters are used to extend the channel length and topology beyond that which could be achieved by a single coaxial cable segment. (See the channel configuration model in 7.1.5.) A repeater requires a transceiver on each of the segments between which it is repeating signals. These transceivers must be as specified in 7.4, and must be counted towards the maximum specified in 7.6.2.

A maximum of two repeaters may be in the signal path between any two transceivers on the channel.

### 7.6.4.1 Carrier Detect and Transmit Repeat

Repeaters must implement the carrier sense function as specified in 7.5.3 for both segments between which it is connected. Upon detection of carrier from one segment, the repeater must retransmit all received signals from that segment onto the other segment. Signals shall be retimed and amplified as specified in 7.6.4.3. The maximum steady-state propagation delay through the repeater for the repeated signal (not including startup delays, carrier sense delay or retiming delays) shall not exceed 800 nS.

### 7.6.4.2 Collision Detect and Collision Repeat

Repeaters must implement the collision detect function as specified in 7.5.2 for both segments between which it is connected. If, while repeating signals as specified in 7.6.4.1, collision is detected on either side, the repeater must ensure that all stations involved in the collision recognize the event as a collision, regardless of which side of the repeater the station is on. The maximum time between the recognition of the collision and the repeating of the collision indication (not including carrier sense or retiming delays) shall not exceed 200 nS.

### 7.6.4.3 Repeater Signal Regeneration

#### 7.6.4.3.1 Signal Amplification

The repeater (with its associated transceivers) shall ensure that any signals repeated between segments shall have the same amplitude characteristics at the transceiver output of the repeated-to segment as they did at the output of the transmitter on the repeated-from segment, allowing for transceiver output tolerances as specified in 7.4.1.3. Any loss of signal-to-noise ratio due to cable loss and noise pickup is thus regained at the output of the repeater.

#### 7.6.4.3.2 Signal Timing

The repeater must ensure that the symmetry characteristics of the signals at the transceiver output of the repeated-to segment are the same as those at the output of the transmitter on the repeated-from segment, allowing for transceiver and transceiver cable tolerances. Any loss of symmetry due to transceivers and cable distortion is thus regained at the output of the repeater.

## **7.7 Environment Specifications**

The following sections specify the physical environment in which all channel components must operate to be considered compatible.

### **7.7.1 Electromagnetic Environment**

The physical channel hardware shall meet its specifications when operating in the following ambient plane-wave fields:

2 Volts/Meter from 10 KHz through 30 MHz

5 Volts/Meter from 30 MHz through 1 GHz

### **7.7.2 Temperature and Humidity**

All physical channel hardware, with the possible exception of the channel logic components shall operate over the ambient temperature range of 5 to 50 degrees Celsius, and humidity range of 10% to 95% non-condensing. The channel logic components are normally part of the station hardware, and are thus subject to individual station product requirements. Hardware which does not meet the temperature and humidity requirements specified must state so in its published product specification.

## APPENDIX A: GLOSSARY

This section defines some of the essential terminology associated with the Ethernet.

*baseband coaxial system:* A system whereby information is directly encoded and impressed on the coaxial transmission medium. One information signal at a time can be present on the medium without disruption (see collision).

*binary exponential backoff:* The algorithm used to schedule retransmissions after a collision. So called because the interval from which the retransmission time is selected is expanded exponentially with repeated collisions.

*broadcast:* Describes the class of media for which the Ethernet is designed, in which all stations are capable of receiving a signal transmitted by any other station. Also, describes the mode of usage of such a medium by the Data Link Layer in which all stations are instructed to receive a given frame.

*carrier sense:* A signal provided by the Physical Layer to the Data Link Layer to indicate that one or more stations are currently transmitting on the channel.

*channel logic:* The logical functions provided between the transceiver cable and the Data Link, which support the defined interface between the data link and the physical layers.

*Client Layer:* Collective term used to describe any layer of a network architecture, which use the Ethernet Data Link and Client interface.

*coaxial cable:* A two-conductor, concentric, constant impedance transmission line.

*coaxial cable interface:* The electrical, mechanical, and logical interface to the shared coaxial cable medium. This is a mandatory compatibility interface, which must be correctly implemented by every Ethernet implementation.

*coaxial cable section:* An unbroken piece of coaxial cable, fitted with coaxial connectors at its ends, used to build up coaxial cable segments.

*coaxial cable segment:* A length of coaxial cable made up from one or more coaxial cable sections and coaxial connectors, terminated at each end in its characteristic impedance. A 500 meter segment is the longest configuration possible without repeaters.

*collision:* The result of multiple transmissions overlapping in the physical channel, resulting in garbled data and necessitating retransmission.

*collision detect:* A signal provided by the Physical Layer to the Data Link Layer to indicate that one or more other stations are contending with the local station's

transmission. It can be true only during transmission.

*collision enforcement:* Transmission of extra, encoded "jam" bits after a collision is detected, to insure that the duration of the collision is sufficient to guarantee its detection by all transmitting stations.

*compatibility interfaces:* The coaxial cable interface, and the transceiver cable interface, the two points at which hardware compatibility is defined to allow connection of independently designed and manufactured components to the Ethernet.

*contention:* Interference between colliding transmissions (see collision). Resolution of occasional contention is a normal part of the Ethernet's distributed link management procedure (see CSMA-CD).

*controller:* The implementation unit which connects a station to the Ethernet, typically comprising part of the Physical Layer, much or all of the Data Link Layer, and appropriate electronics for interfacing to the station.

*CSMA-CD:* Carrier Sense Multiple Access with Collision Detection, the generic term for the class of link management procedure used by the Ethernet. So called because it a) allows multiple stations to access the broadcast channel at will, b) avoids contention via carrier sense and deference, and c) resolves contention via collision detection and retransmission.

*Data Link Layer:* The higher of the two layers in the Ethernet design, which implements a medium-independent link level communication facility on top of the physical channel provided by the Physical Layer.

*deference:* A process by which a data link controller delays its transmission when the channel is busy to avoid contention with ongoing transmissions.

*frame check sequence:* An encoded value appended to each frame by the Data Link Layer to allow detection of transmission errors in the physical channel.

*interframe spacing:* An enforced idle time between transmission of successive frames to allow receiving data link controllers and the physical channel to recover.

*jam:* An encoded bit sequence used for collision enforcement.

*Manchester encoding:* A means by which separate data and clock signals can be combined into a single, self-synchronizable data stream, suitable for transmission on a serial channel.

*multicast:* An addressing mode in which a given frame is targeted to a group of logically related stations.

*physical address:* The unique address value associated with a given station on the network. An Ethernet physical address is defined to be distinct from all other physical addresses on all Ethernets.

*Physical Channel:* The implementation of the physical layer.

*Physical Layer:* The lower of the two layers of the Ethernet design, implemented by the physical channel using the specified coaxial cable medium. The Physical Layer insulates the Data Link Layer from medium-dependent physical characteristics.

*preamble:* A sequence of 64 encoded bits which the Physical Layer transmits before each frame to allow synchronization of clocks and other Physical Layer circuitry at other sites on the channel.

*repeater:* A device used to extend the length and topology of the physical channel beyond that imposed by a single segment, up to the maximum allowable end-to-end channel length.

*round-trip propagation time:* In bit times, the time required in the worst-case for a transmitting station's collision detect signal to be asserted due to normal contention for the channel. This delay is the primary component of the slot time.

*slot time:* A multi-purpose parameter which describes the contention behavior of the Data Link Layer. It serves as a) an upper bound on the collision vulnerability of a given transmission, b) an upper bound on the size of the frame fragment produced by a collision, and c) the scheduling quantum for collision retransmission.

*station:* A single addressable site on the Ethernet, generally implemented as a computer and appropriate peripherals, and connected to the Ethernet via a controller and a transceiver.

*transceiver:* The portion of the Physical Layer implementation that connects directly to the coaxial cable and provides both the electronics which send and receive the encoded signals on the cable and the required electrical isolation.

*transceiver cable:* A four pair, shielded cable used for the transceiver cable interface.

*transceiver cable interface:* The electrical, mechanical and logical interface which connects the transceiver to the controller. The standard transceiver cable is a recommended compatibility interface.

**APPENDIX B: NOTES ON ADDRESS AND TYPE ASSIGNMENT, AND LICENSING****Address and Type Assignment**

The address and type fields will be administered by Xerox Corporation.

A block of addresses will be assigned to each licensee of Ethernet patents (see below). Others may obtain an address block or type field assignment by request. A nominal fee to cover administrative costs will be charged.

Submit written requests to:

Xerox Corporation  
Ethernet Address Administration Office  
3333 Coyote Hill Road  
Palo Alto, CA 94304

**Licensing**

Ethernet incorporates features that are protected by one or more patents assigned to Xerox Corporation. Questions on the need for licensing particular uses of this specification should be directed to:

Xerox Corporation  
Director of Licensing  
Long Ridge Road  
Stamford, CT 06904

## APPENDIX C: CRC IMPLEMENTATION

Every frame contains, in its frame check sequence field, a 32-bit cyclic redundancy check (CRC) code. Because the formal mathematical definition of this code (see 6.2.4) is not suggestive of an appropriate implementation, this appendix outlines one possible implementation in terms of a feedback shift register. This type of implementation is likely to be common in practice, but is not a mandatory part of the specification.

The feedback shift register (see Figure C-1) is used to represent division of the pre-scaled message by the generating polynomial. The 32-bit register is accessed via the three signals Input, Output, and Control. When Control = 1, Input bits are shifted into the feedback shift register and also fed directly back to Output. When Control = 0, the feedback paths are disabled and the shift register shifts the complement of its contents to Output.

Before CRC generation at the transmitting end, initialization logic (not shown in Figure C-1) preloads the shift register to all 1's. Control is then held at 1 while the address, type and data fields of the outgoing frame are shifted into Input and the CRC is generated. Meanwhile, the same bits emerging at Output are transmitted over the network. When the last bit of the data field has been processed, Control is set to 0 and the complemented CRC is shifted out for transmission, starting with the  $x^{31}$  term (see 6.2.4).

CRC checking at the receiving end also begins with the shift register preloaded to all 1's. Control is then held at 1 while the incoming bits are shifted into Input to regenerate the CRC. When the last bit of the data field has been processed, the shift register should contain the CRC whose binary complement is about to arrive on the network. Since this field boundary cannot be recognized by the receiver, however, Control remains at 1 and the bits of the CRC continue to feed into the the shift register until the end of the entire frame is reached. If the two CRCs match, the final contents of the shift register is the value:

11000111 00000100 11011101 01111011

(where the leftmost bit corresponds to the  $x^{31}$  term of the polynomial and the rightmost to the  $x^0$  term). Any other final value indicates a detected error. (The extra logic to test for this value is not shown in Figure C-1).



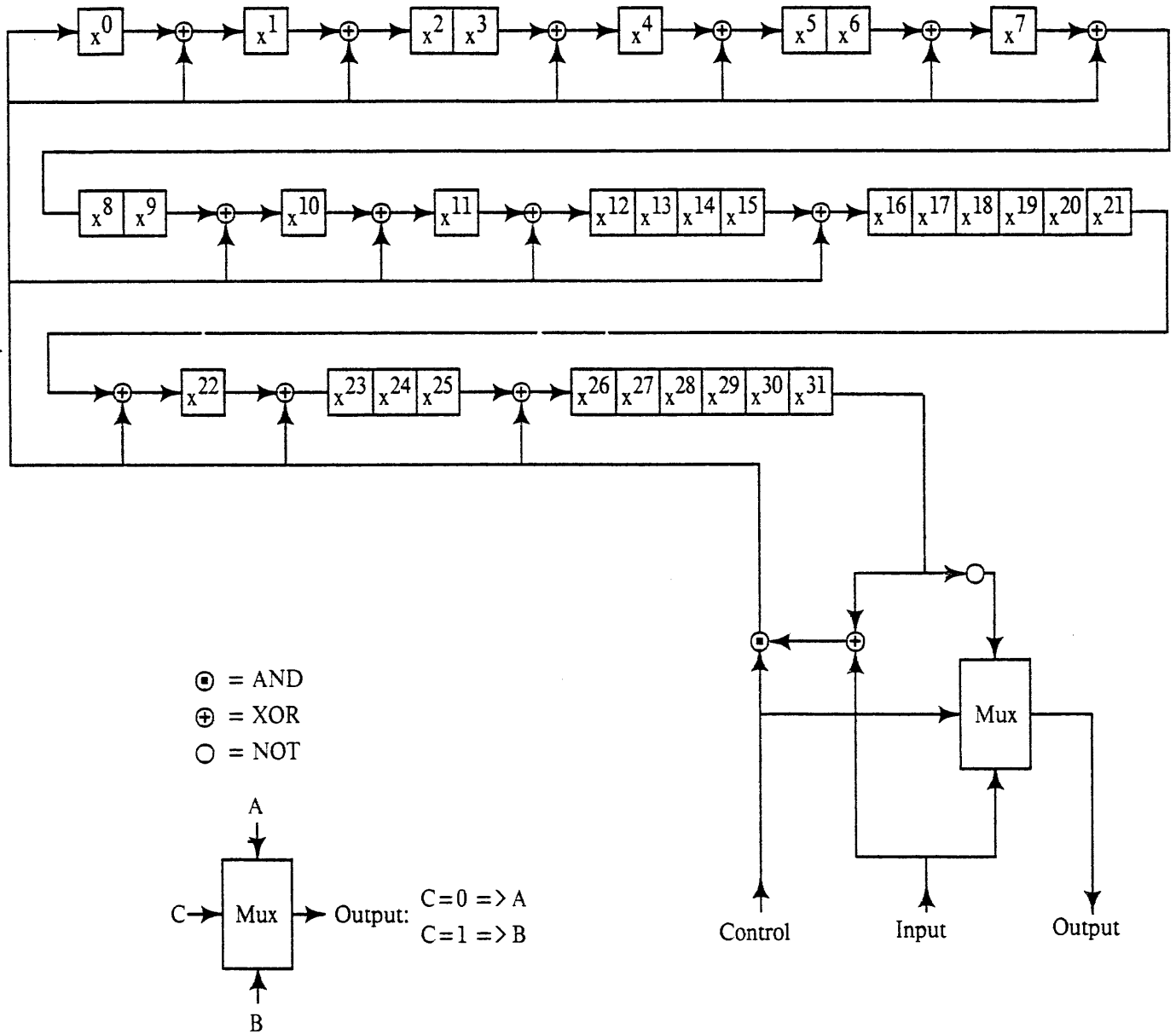

Figure C-1: CRC Implementation

One potential problem which is avoided in this implementation is insensitivity of the shift register to incoming zero-bits when it is in the all-zero state. Following standard practice, this state is avoided at the beginning and end of the frame by preloading the shift register with all 1-bits, and by inverting each bit of the final CRC. Logically, these correspond, respectively, to the complementing of the first 32 bits of the frame and to the final complementing of the remainder, as specified in the mathematical definition in 6.2.4. See also [9] for further discussion.

## APPENDIX D: IMPLEMENTATION OF TRANSCEIVER CABLE DRIVER AND RECEIVER

This appendix presents circuit diagrams for typical implementations of the transceiver cable drivers and receivers. The use of these exact circuits is not necessary for conformance to the specification; equivalent circuits may be used as long as the relevant specifications are met.

Figure D-1 depicts an implementation of the transceiver cable driver specified in 7.2.4. It is suitable for use at either end of the transceiver cable, as necessary; i.e., it would be located at the station end to drive the transmit pair, and at the transceiver end to drive the receive and collision presence pairs. In addition, it is capable of driving suitable isolation circuits required to be located within the transceiver.

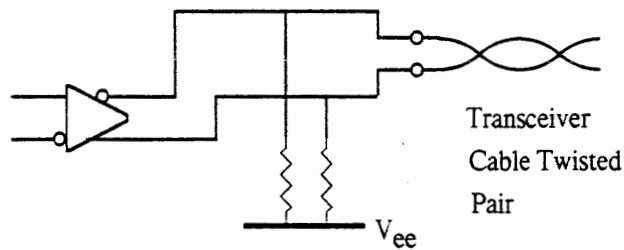

Figure D-1: Typical Transceiver Cable Driver

Figure D-2 depicts an implementation of the transceiver cable receiver specified in 7.2.5. It is suitable for use at either end of the transceiver cable, as necessary; i.e., it would be located at the station end to receive from the receive and collision presence pairs, and at the transceiver to receive from the transmit pair. It is capable of operating through suitable isolation circuits required to be located within the transceiver.

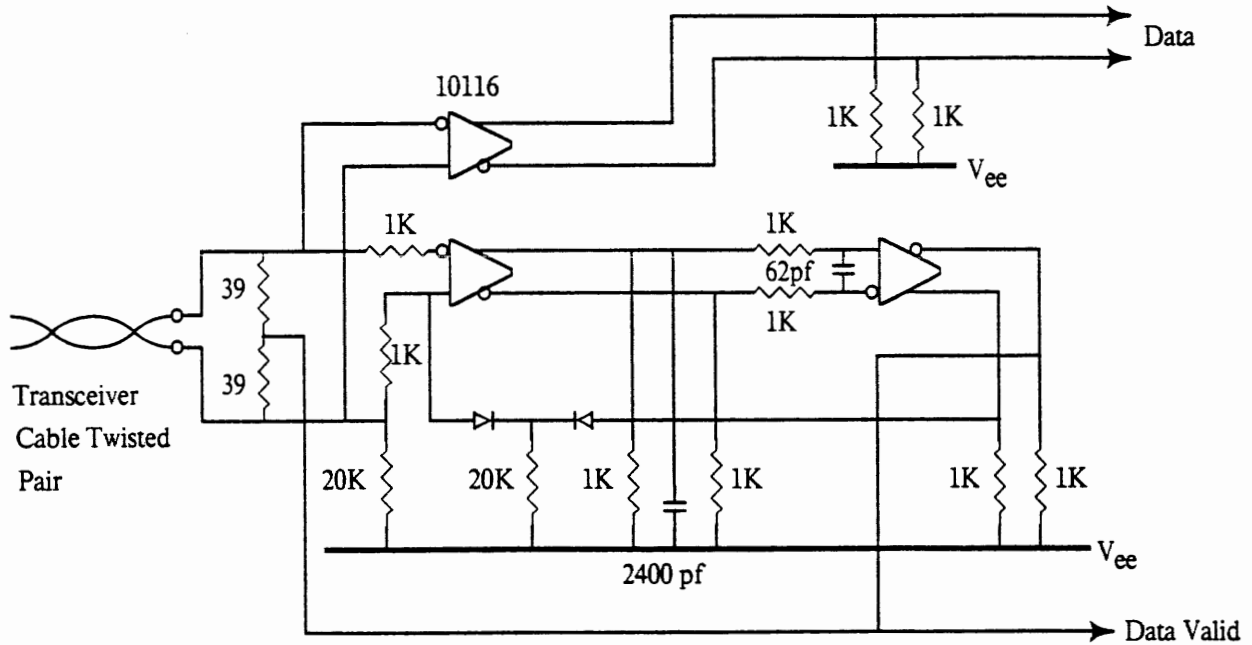

Figure D-2: Typical Transceiver Cable Receiver

#### APPENDIX E: INTERFRAME RECOVERY

It is important that data link controller implementations be able to receive a frame that arrives immediately after another frame has been transmitted or received. Here, "immediately" means 9.6  $\mu$ sec, based on the minimum interframe spacing provided as recovery time for the data link. (See 6.3.2.2) It is important that the data link controller be able to resume reception within that time.

Reception of multiple closely spaced incoming frames is a very desirable capability, and is crucial for stations which tend to communicate with several other stations concurrently. There is one important case in which a data link controller implementation cannot reasonably be expected to receive closely spaced incoming frames: if the station hardware (e.g. I/O bus) is intrinsically unable to accept the bits of a frame at the rate at which they arrive over the network, each incoming frame must be buffered to allow the station to accept it at some lower rate. Assuming limited buffering resources (e.g. a one frame buffer), reception of subsequent frames cannot occur until sufficient buffer space is available. This mode of operation is allowed for low performance stations.

Reception of an incoming frame immediately after transmission of an outgoing frame is a very important capability, even for stations which do not tend to communicate with several other stations concurrently. All stations, low performance to high performance, should allow reception of an incoming frame immediately after transmission of an outgoing frame.



INTEL CORPORATION, 3065 Bowers Avenue, Santa Clara, CA 95051 (408) 987-8080