

[54] **FLAT COMPOSITE FLUORESCENT DISPLAY TUBE**
 [75] Inventor: **Mikiharu Tanji**, Ise, Japan
 [73] Assignee: **ISE Electronics Corporation**, Ise City, Japan
 [22] Filed: **Dec. 8, 1970**
 [21] Appl. No.: **96,025**

[30] **Foreign Application Priority Data**
 Dec. 13, 1969 Japan44/99882

[52] U.S. Cl.**313/108 R**, 313/109.5, 313/273, 313/278
 [51] Int. Cl.**H01j 1/72**, H01j 1/88, H01j 63/00
 [58] Field of Search...313/109.5, 273, 278, 348, 318, 313/108 R

[56] **References Cited**
UNITED STATES PATENTS
 3,571,655 3/1971 Tanimoto313/109.5 X
 2,538,669 1/1951 Coeterier313/348 X
 3,330,982 7/1967 Dickson, Jr.313/318 X
 2,908,842 10/1959 Kuffer313/278
 3,408,523 10/1968 Demarest et al.313/109.5

3,418,509 12/1968 Frouws et al.313/109.5

Primary Examiner—Palmer C. Demeo
Attorney—Chittick, Pfund, Birch, Samuels & Gauthier

[57] **ABSTRACT**

In a composite fluorescent display tube of the type comprising an insulator substrate, a plurality of display members mounted on one surface of the substrate, each of the display members including a plurality of fluorescent segments which are selectively energized to display a selected letter, a filament confronting these plurality of display members, and a evacuated envelope containing the above described component parts, there are provided a plurality of independent electrode structures, one for each one of the display members, each electrode structure including a letter forming electrode having a plurality of perforations corresponding to the fluorescent segments, a mesh control grid electrode and a frame shaped electrode interposed between the letter forming electrode and the control grid electrode for connecting them into a unitary structure; and conductors common to corresponding ones of the fluorescent segments of the display members, said conductors extending along the opposite surface of the substrate.

6 Claims, 9 Drawing Figures

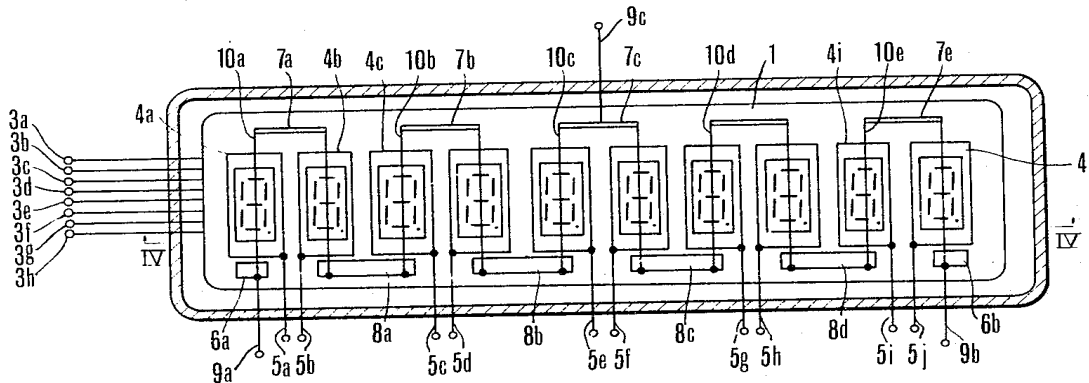

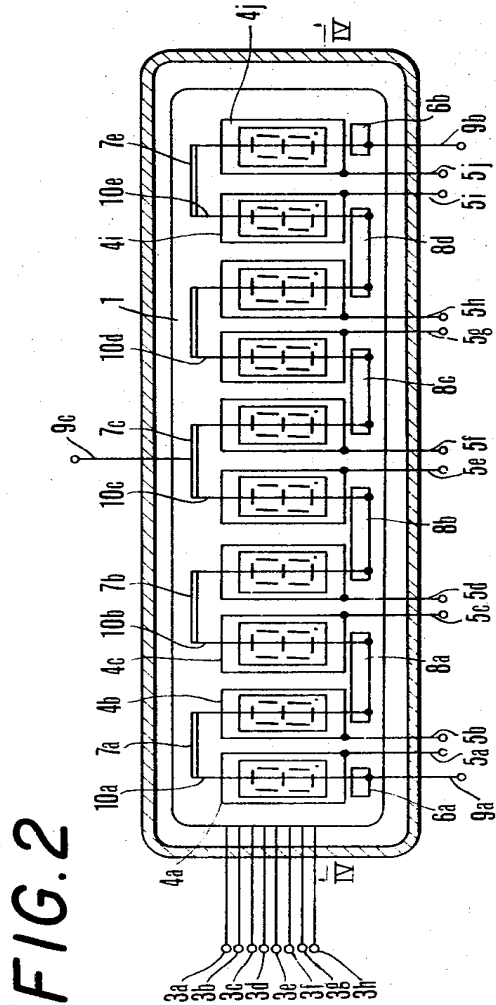
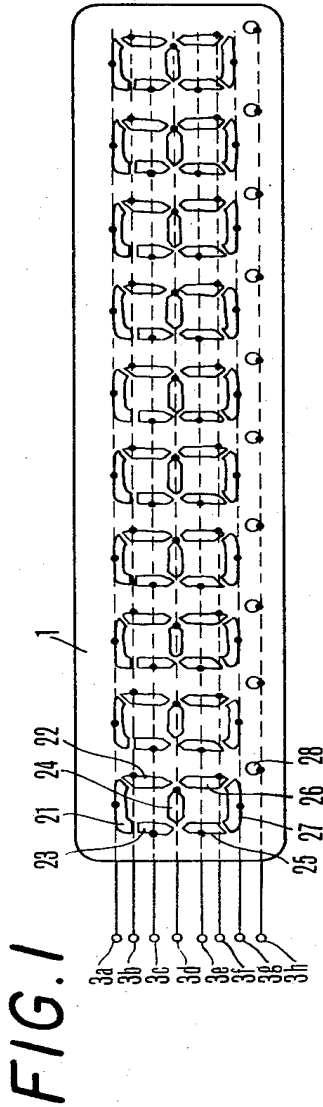

INVENTOR
MIKIHARU TANJI

BY *Chittick, Pfund, Birch,
Samuels & Gauthier*
ATTORNEY

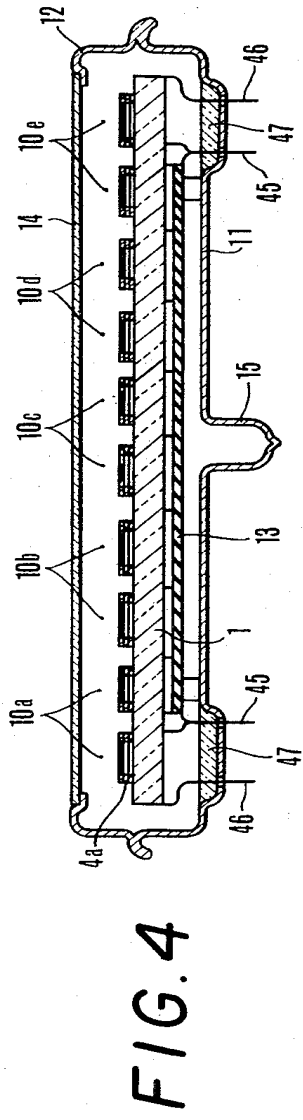
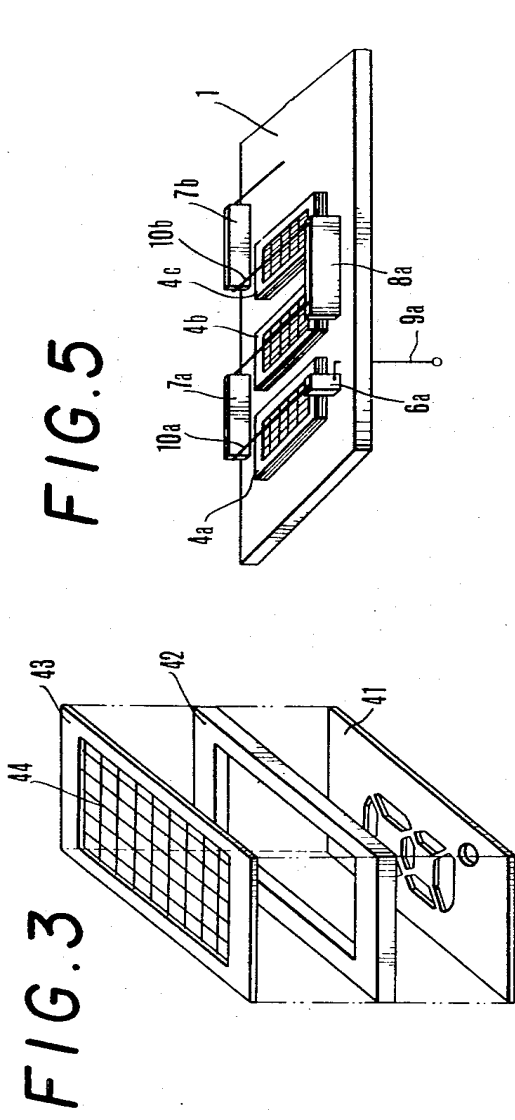

INVENTOR
MIKIHARU TANJI

BY *Chittick, Pfund, Birch,
Samuels & Gauthier* ATTORNEY

FIG. 6

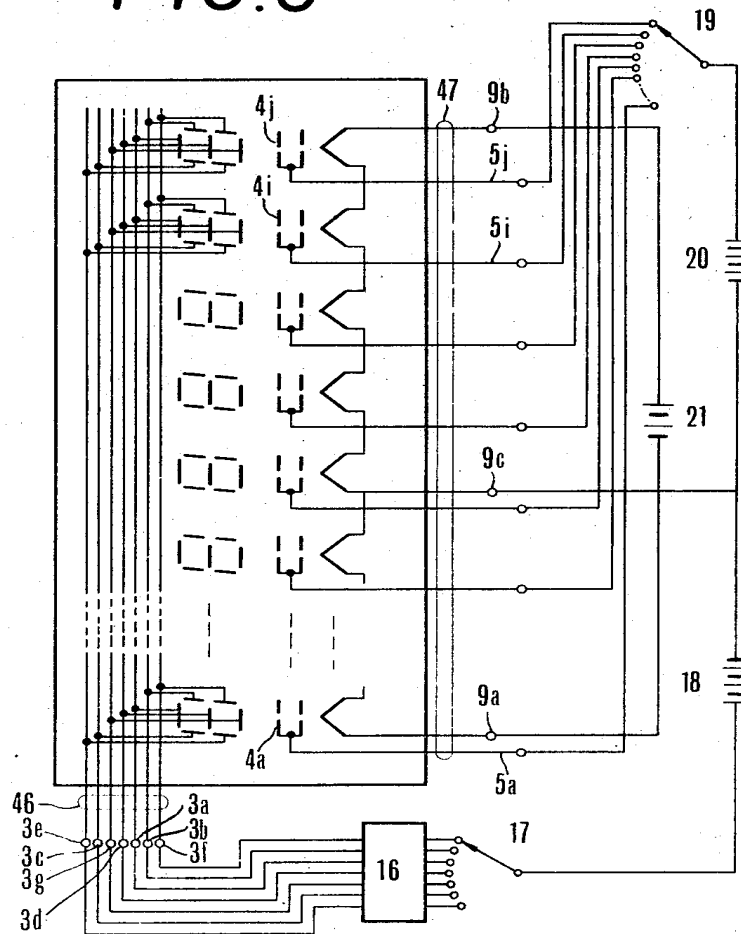

INVENTOR
MIKIHARU TANJI

BY *Chittick Pfund, Birch,
Samuels & Gauthier*
ATTORNEY

FIG. 7

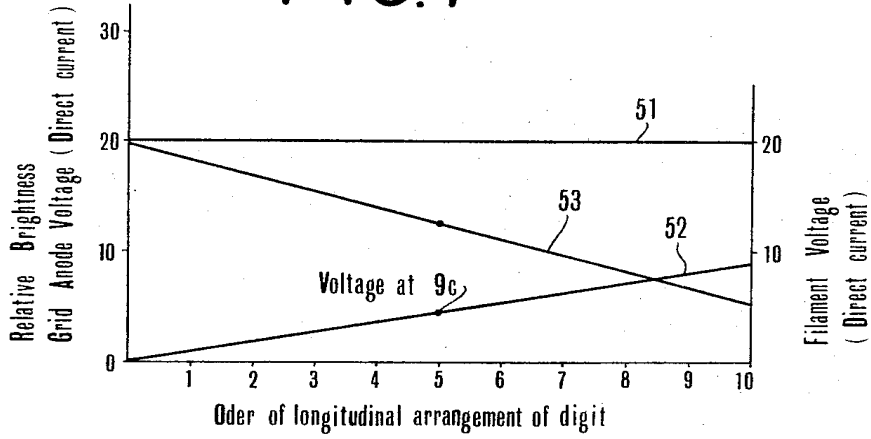

FIG. 8

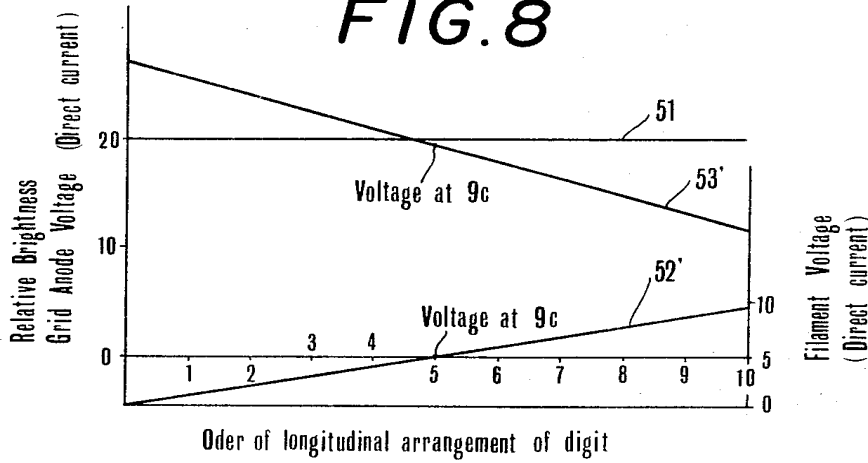
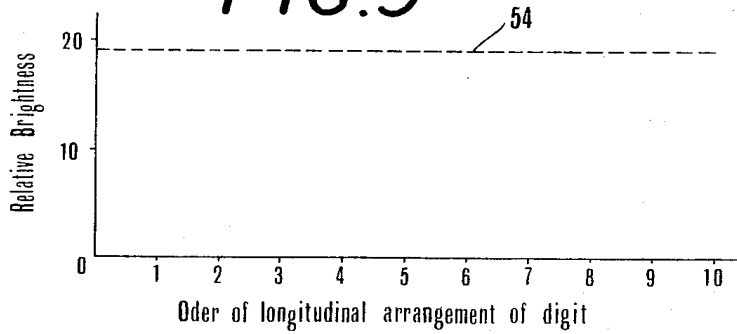

FIG. 9



INVENTOR
MIKIHARU TANJI

BY *Chittick, Pfund, Birch, Samuels & Gauthier*
ATTORNEY

FLAT COMPOSITE FLUORESCENT DISPLAY TUBE

BACKGROUND OF THE INVENTION

This invention relates to a flat fluorescent display tube and more particularly to a flat composite fluorescent display tube wherein a plurality of letters, symbols and or numeral display members are disposed in a single evacuated envelope so as to simultaneously display letters, numerals and the like of any desired number.

Fluorescent display tubes have been known wherein a plurality of luminescent segments which are selectively energized to form a single letter or digit are sealed in a common evacuated envelope. Since a plurality of fluorescent segments of such a fluorescent display tubes are disposed on the same plane there are such advantages that it is easy to read fluorescent letters and the like and that it is possible to operate the tube with a relatively low voltage. Such fluorescent display tubes are used as the answer display means of table type electronic computers, for example. Since the answers, or the results of calculations of the computers generally have a plurality of orders of magnitudes, it is necessary to employ a plurality of display tubes. When arranging a plurality of fluorescent tubes, there arises the problem of space factor so that sealing a plurality of display members adapted to display a plurality of orders in a common evacuated envelope is advantageous from the viewpoint of simplifying the wiring as well as the space factor. Exhaustive investigations have been made in the past to accomplish this object.

However, until now no satisfactory composite fluorescent display tube has been developed. There are many problems left to be solved including miniturization of the envelope, improving the brightness of the fluorescent light, provision of shields for preventing undesirable luminescence of adjacent letters and the construction of a common cathode electrode.

SUMMARY OF THE INVENTION

It is an object of this invention to solve various problems of the composite type fluorescent display tube described above so as to provide flat composite fluorescent tubes of high practical values.

Another object of this invention is to provide a novel flat composite fluorescent display tube having a filament of improved construction that miniaturizes the tube.

Still another object of this invention is to provide a novel composite fluorescent tube having an evacuated envelope which can be fabricated by welding without affecting the component elements contained in the envelope.

Yet another object of this invention is to provide a novel flat composite fluorescent display tube having a resiliently supported filament whereby elongation of the filament due to heat can be compensated for and the filament can be prevented from breakage.

Further object of this invention is to provide a novel composite fluorescent display tube having electrode structures including letter forming electrodes that act as a screen grid to sharply define the displayed letter or digit.

Still further object of this invention is to provide an improved composite fluorescent display tube having a

plurality of electrode structures, each including a letter forming electrode and a control grid interconnected by a frame electrode that functions as a shield for preventing electrons accelerated by the control grid from reaching adjacent display members or electrode structures thus eliminating the necessity of providing shields between adjacent display members.

Further object of this invention is to provide an improved composite display tube wherein the difference in the brightness of a plurality of display members which are arranged along a straight line to display decimal numerals of multi-orders can be minimized.

In accordance with this invention in a composite fluorescent display tube of the type comprising an insulator substrate, a plurality of display members mounted on one surface of the substrate, each of the display members including a plurality of fluorescent segments which are selectively energized to display a selected letter, a filament confronting these plurality of display members, and an evacuated envelope containing above described component parts, there are provided a plurality of independent electrode structures, one for each one of the display members; each electrode structure including a letter forming electrode having a plurality of perforations corresponding to the fluorescent segments, a mesh control grid electrode and a frame shaped electrode interposed between the letter forming electrode and the control grid electrode for connecting them into a unitary structure; and conductors common to corresponding ones of the fluorescent segments of the display members, said conductors extending along the opposite surface of the substrate.

According to another feature of the invention the filament comprises a plurality of serially connected filament segments, each traversing one of the electrode structures and supported by a metal resilient support. The filament segments are connected in series through metal supports. An auxiliary electrode is connected at an intermediate point of the filament and a zero reference potential of the display tube is impressed upon the auxiliary electrode to decrease the difference in the brightness of a plurality of display members.

BRIEF DESCRIPTION OF THE DRAWING

The invention can be more fully understood from following detailed description taken in conjunction with the accompanying drawings in which:

FIG. 1 is a plan view of an insulator substrate to be sealed in a display tube of this invention and is provided with a plurality of fluorescent segments which are selectively energized to form a plurality of letters or digits;

FIG. 2 is a plan view of the display tube with the upper cover removed to clearly show the internal construction;

FIG. 3 is a perspective exploded view of one example of a group of electrodes employed in this invention.

FIG. 4 is a sectional view, with portions being removed, of the display tube shown in FIG. 2 taken along a line IV — IV';

FIG. 5 is a perspective view, partly broken array, of a substrate mounted with a cathode filament;

FIG. 6 shows one example of the connection diagram of the display tube and

FIGS. 7 to 9 show characteristic curves to explain the operation of the display tube.

DESCRIPTION OF THE PREFERRED EMBODIMENT

With reference now to FIG. 1 there is shown a substrate 1 of insulator such as ceramic, for example, and a plurality of groups of segments for composing letters or digits. In the example shown there are 10 digit display members for displaying numerals of 10 orders. Each digit comprises seven fluorescent segments 21 to 27 and to each digit is associated a segment 28 for displaying a decimal point. As is well known in the art each segment is composed of a fluorescent substance which is coated upon a segment electrode (not shown) secured or cemented to the substrate. For the sake of convenience, a group of eight segments 21 to 28 inclusive is herein termed as a display member for displaying one digit. According to this invention corresponding ones of segment electrodes of 8 segments comprising respective display members are electrically connected into one group, the terminals thereof being designated by 3a and 3b in FIG. 1. The points of connection between respective segments belonging to one group and the associated circuit are shown by black spots in FIG. 1. According to this invention, the connection circuit or conductors extend along the rear surface of the substrate 1 as shown by dotted lines.

The substrate 1 provided with the segments and with the connecting conductors are sealed in an evacuated envelope as shown in FIG. 2. Respective display members are provided with independent electrode structures 4a - 4j. As shown by the exploded perspective view shown in FIG. 3 each of the electrode structures comprises a digit forming electrode 41, a rectangular frame like support 42, and a wire mesh like control grid electrode 43, each of which is made of electroconductive metal. As shown, the digit forming electrode 41 is formed with 8 openings corresponding to respective segments 21 to 28 so as to define a selected digit or letter to be displayed. Also the electrode 41 functions to shield the digit display member from the electric field prevailing on substrate 1 and to absorb substances evaporated from the cathode electrode so as to elongate the operating life of the display member. The supporting frame 42 functions to securely support digit forming electrode 41 and control grid electrode 43 at a definite spacing which is determined by the thickness of the support 42. The mesh like control electrode 43 comprises a mesh grid 44 which may be formed by knitting fine metal wires or by photoetching a metal plate. Electrodes 41, 43 and support 42 may be connected together by electric welding for example so that perforations of digit forming electrode 41 confront corresponding segments of a display member on the substrate. Electrode structures secured in this manner are connected with lead wires 5a through 5j, respectively, which may extend along the upper surface of the substrate 1 or extend through openings therein to project to the rear side of the substrate.

As is well known in the art, the fluorescent display tube is provided with a cathode filament in front of the display member and in parallel with the surface thereof. The mounting of the cathode electrode of the novel composite fluorescent display tube is shown in FIGS. 2 and 5. According to this invention, electroconductive filament supports are secured on the substrate. More particularly, as shown in FIG. 5, support 6a is secured on the substrate 1 in front of the first electrode

assembly 4a and is connected to a terminal 9a extending through substrate 1. Another support 8a is provided in front of the second and third electrode assemblies 4b and 4c so as to bridge them. In the same manner, a support 8b is secured in front of the third and fourth electrode assemblies 4d and 4e to bridge them, and so on. A support 6b similar to support 6a is secured to the substrate in front of the right most electrode assembly 4j and the support 6b is connected to a terminal 9b, similarly extending through the substrate. Resilient electroconductive supports 7a to 7e (made of leaf springs, for example) are secured to the rear of electrode assemblies 4a to 4j, each bridging two adjacent electrode assemblies. Each end of respective supports 7a to 7e terminates at substantially the midpoint of the associated electrode assembly for the reason to be described later. The cathode filament is mounted on these supports in the following manner.

In this embodiment filaments 10a to 10e for 10 display members are comprised by five filament segments 10a through 10e. As the mounting means of these filament segments upon respective supports are identical, the mounting means of segment 10a alone will be described in detail. Thus, one end of filament segment 10a is welded to the upper end of support 6a and is then bent around the outer surface of resilient support 7a. The opposite end of filament segment 10a is welded to support 8a as shown in FIG. 2. This weld is made while the filament segment 10a is slightly bent about resilient support 7a so as to maintain filament segment 10a under tension by the restoring force of the resilient support 7a. As above described, the opposite ends of resilient support 7a are terminated at substantially the centers of electrode assemblies 4a and 4b respectively so that it is possible to locate the filament segment 7a between center lines of electrode assemblies 4a and 4b by proper selection of welding positions between filament segment 7a and supports 6a and 8a. In the same manner, each of the remaining filament segments 10b and 10e is passed about a resilient support and the opposite ends of the segment are welded to two adjacent supports, so that each segment is always under tension. Thus, terminals 9a and 9b connected to supports 6a and 6b are electrically interconnected through serially connected filament segments. A filament source, not shown, is connected across terminals 9a and 9b. According to this invention, an auxiliary terminal 9c is connected to the filament circuit at any point between terminals 9a and 9b, preferably at the mid point of the filament of the filament circuit. Although the purpose of the auxiliary terminal 9c will be described later, it may be welded to resilient support 10c, as shown in FIG. 2 or to either one of supports 8b and 8c.

FIG. 4 shows a longitudinal sectional view of the assembly assembled on the substrate in the manner as above described and sealed in an evacuated envelope, portions being omitted for the sake of clearness. The evacuated envelope comprises a lower vessel 11 and an upper vessel 12, each of metal. A plate 13 is secured in the lower vessel 11 to guide terminals. More particularly, terminals 5a through 5j of electrode assemblies 4a through 4j are secured to plate 13 after extending through substrate 1, and groups of several terminals are led out of the envelope as at 45. Above described terminals 3a and 3b of the groups of luminous segments

extending along the rear surface of the substrate 1 are led out of the envelope at the opposite ends thereof as at 46. These lead wires 45 and 46 extends through air tight glass seals 47 which are sealed to the lower vessel 11. A transparent or translucent window of glass, for example is secured facing the display members on the upper side of upper vessel 12 which is made of metal and provided with a peripheral flange. The upper vessel 12 is mounted upon the lower vessel 11 with their outwardly projecting peripheral flanges aligned which are sealed together by welding or injection welding. Thereafter, the interior of the envelope is evacuated through an exhaust pipe 15 which is sealed off after completion of the evacuation to complete a composite fluorescent display tube of this invention. Although not shown in the drawing, suitable getter supports are secured to terminal guide plate 13 and the substrate 1 to maintain a high vacuum in the envelope.

The operation of the novel display tube will now be described with reference to the connection diagram shown in FIG. 6. Terminals 3a and 3b commonly connected on the rear surface of the substrate to groups of luminous segment electrodes corresponding to respective digits are connected to output terminals of a digit (or letter) synthesizer 16, input terminals thereof being connected to the positive pole of a plate source 18 (of 20 volts, for example) through a transfer switch 17. On the other hand, terminals 5a through 5j of electrode structures 4a through 4j are connected to the positive pole of a control electrode source 20 (of 20 volts, for example) through another transfer switch 19 and a cathode source 21 (of 9 volts, for example) is connected between filament terminals 9a and 9b. The auxiliary terminal 9c is connected to the juncture between negative poles of sources 18 and 20.

Suppose now that it is desired to display a digit "1", transfer switch 17 is connected to an input terminal corresponding to digit "1" of the digit synthesizer 16 to supply a positive potential to circuit terminals connected to segments composing the digit "1" among various groups of digit segments. The transfer switch 19 is used to determine the order of magnitude at which the digit "1" is to be displayed. Thus, for example, when it is desired to cause the first display member from the left as viewed in FIG. 2 to display the digit "1" terminal 5a connected to the electrode structure 4a is selected. Electrons emanated from the filaments are attracted and accelerated by mesh shaped control grid electrode 43 supplied with positive potential and are diffused thereby toward the digit forming electrode 41. After passing through perforations of digit forming electrode 41 the electrons collide upon particular luminous segments which are impressed with positive potential through digit synthesizer 16 thus causing the segments to luminesce to display a digit "1." Where it is desired to display a digit "1" on another order of magnitude, another electrode assembly located at that order is selected by the transfer switch 19. Further when it is desired to display another digit the transfer switch 17 is switched to excite luminous segments corresponding to the desired digit.

The purpose of the auxiliary terminal 9c, one of the features of this invention, will now be considered. In the absence of the auxiliary terminal, the grid-anode voltage characteristic has a constant value (20 volts,

for example) as shown by a straight line 51, FIG. 7. The voltages of the filament segments corresponding to respective digits are different according to the order of the longitudinal arrangement of the digits. In other words, segments closer to the positive pole of the filament source have higher potentials as shown by a straight line 52, shown in FIG. 7. Whereas, the brightness of the luminous segments is proportional to the difference between the grid-anode voltage and the filament voltage as shown by a straight line 53. Connection of the auxiliary terminal 9c is to the negative pole of the cathodes source or to the negative pole of the anode source or of the control grid source, so that application of the zero reference voltage of the grid-anode voltage upon the auxiliary terminal results in the relative decrease in the filament potential as shown by a straight line 52' shown in FIG. 8. Consequently, the brightness characteristic can be shown by a straight line 53' which shows substantial increase in the brightness of the luminous segments thus decreasing the difference between display tubes at the highest and lowest orders. Where an alternating current is used as the filament source, as the potential of the filament reverses at each half cycle of the AC source the mean value of the potential is represented by a horizontal line so that the brightness characteristics will be shown by a dotted horizontal line 54, in FIG. 9. Although in the foregoing description, DC sources are used to drive luminous display tubes it will be clear that it is also possible to use pulse voltages. As is well understood by those skilled in the art, where pulses are used, decimal pulses are supplied to the input of digit synthesizer 16 for each display tube concurrently with the application of a timing pulse voltage to the control grid corresponding the desired digit in synchronism with the input pulse.

Having now completed the description of a preferred embodiment of the invention, the advantageous merits of this invention are enumerated in the following.

DIMENSIONS OF THE DISPLAY TUBE

As the conductors connected to luminous segment electrodes and circuit terminals connected to the electrodes and supports on the substrate are disposed to extend along the rear surface of the substrate, it is possible to decrease the width of the substrate. Moreover as respective filament segments are disposed at right angles with respect to the direction of arrangement of respective digits and since the filament is not fixed in that direction it is possible to decrease the overall length of the display tube, thus miniaturizing the same.

ENVELOPE OF THE DISPLAY TUBE

As the evacuated envelope is formed by sealing together by welding coupling flanges of upper and lower vessels of metal it is easy to fabricate a display tube having a plurality of orders of magnitude. In addition, transfer of the heat of welding to the inside electrodes can be effectively prevented thus preventing oxidation of the internal elements as well as producing rejects.

FILAMENT

Since the filament is comprised by a plurality of discrete segments which are connected in series across the

filament source and since each of the segments is bent about a resilient support with the opposite ends passing over adjacent digits, the elongation of the filament caused by heat is well compensated for by the resiliency of the resilient support whereby the filament segments are maintained straight and in parallel with the electrode assemblies. The filament segments for respective orders are held by the resilient supports which act to absorb external vibrations thus preventing breakage of the filament.

ELECTRODE STRUCTURE

According to this invention, since independent electrode structures are provided for respective digits or letters and since the digit forming electrode of each electrode structure also acts as a screen grid it is possible to clearly define the digit and to improve the life of the luminous segment. Further, as the mesh control electrode and the digit forming electrode are connected together by a frame electrode interposed therebetween there is provided a shielding effect which prevents electrons accelerated by the control grid from reaching other adjacent display members. For this reason, it is not necessary to provide shielding plates between respective letters or digits which have been essential to prior composite display tubes.

BRIGHTNESS

As above described, an auxiliary terminal is connected to the midpoint of a filament comprising a plurality of filament segments, each bent into a letter C configuration, and the potential of the midpoint is maintained at the zero reference potential of the grid-anode voltage so that it is possible to increase the relative difference between the filament voltage and the grid-anode voltage. This increases the brightness so as to substantially decrease the difference in the brightness at the highest and lowest orders. Although in the foregoing embodiment, the auxiliary terminal is shown as being connected to the midpoint of the filament it may be connected to any point intermediate the terminals of the filament. In the case of multi-order display a plurality of auxiliary contacts may be provided.

Thus, this invention provides a novel composite fluorescent display tube free from various defects of prior composite display tubes.

While the invention has been shown and described in terms of a preferred embodiment thereof it will be clear that the invention is never limited to the particular embodiment illustrated and that many changes and modification will be apparent to one skilled in the art without departing from the true spirit and scope of the invention as defined in the appended claims, wherein the term "letter" is used to cover not only a letter, but also a digit or a symbol which can be formed by selective energization of a member of luminous segments.

What is claimed is:

1. A flat composite fluorescent display tube comprising an insulator substrate, a plurality of display members arranged to display a plurality of letters and mounted on one surface of said substrate, each of said display members including a plurality of fluorescent segments which are selectively energized to display a selected letter; a cathode filament comprising a plurality of filament segments confronting said plurality of

display members; an evacuated envelope containing the above described component parts and having a transparent or translucent window facing said display members; a plurality of independent electrode structures for selectively attracting electrons from said filament, one electrode structure being provided for each one of said display members, each of said electrode structures including a letter forming electrode having a plurality of perforations corresponding to said fluorescent segments, a mesh control grid electrode and a frame shaped electrode interposed between said letter forming electrode and said control grid electrode for connecting them into a unitary structure; conductors common to corresponding ones of said fluorescent segments of said display members, said conductors extending along the opposite surface of said substrate; a plurality of resilient metal supports on one side of said display members; a plurality of metal supports on the other side of said display members, each said filament segment connected at one end thereof to one of said metal supports passing around one of said resilient metal supports and connected at the opposite end to another one of said metal supports as to be positioned above two adjacent electrode structures, said plurality of filament segments being connected in series through said metal supports; and at least one auxiliary electrode provided for said filament at an intermediate point thereof, said auxiliary electrode being maintained at a zero reference potential of said display tube so as to decrease apparent differences in the brightness of said display members.

2. A flat composite fluorescent display tube comprising an insulator substrate, a plurality of display members arranged to display a plurality of letters and mounted on one surface of said substrate, each of said display members including a plurality of fluorescent segments which are selectively energized to display a selected letter; a cathode filament confronting said plurality of display members; an evacuated envelope containing the above-described component parts and having a transparent or translucent window facing said display member; a plurality of independent electrode structures for selectively attracting electrons from said filament, one electrode structure being provided for each one of said display members; said filament comprising a plurality of filament segments which are positioned above respective electrode structures, said plurality of filament segments being connected in series; and at least one auxiliary electrode provided for said filament at an intermediate point thereof, said auxiliary electrode being maintained at a zero reference potential of said display tube so as to decrease apparent differences in the brightness of said display members.

3. The composite fluorescent display tube according to claim 2 wherein said evacuated envelope comprises a lower metal vessel having an outwardly projecting peripheral flange, and an upper metal vessel having an outwardly projecting peripheral flange welded to said peripheral flange of said lower vessel.

4. The composite fluorescent display tube according to claim 2 wherein each of said electrode structures includes a letter forming electrode having a plurality of perforations corresponding to said fluorescent segments, a mesh control grid electrode and a frame shaped electrode interposed between said letter form-

ing electrode and said control grid electrode for connecting them into a unitary structure, and further comprising conductors common to corresponding ones of said fluorescent segments of said display members, said conductors extending along the opposite surface of said substrate.

5. A composite fluorescent display tube comprising an insulator substrate, a plurality of display members arranged to display a plurality of letters and mounted on one surface of said substrate, each of said display members including a plurality of fluorescent segments which are selectively energized to display a selected letter; a cathode filament comprising a plurality of filament segments confronting said plurality of display members; an evacuated envelope containing the above-described component parts and having a transparent or translucent window facing said display members; a plurality of independent electrode structures for selectively attracting electrons from said filament, one electrode

structure being provided for each one of said display members; a plurality of resilient metal supports on one side of said display members; a plurality of metal supports on the other side of said display members; each said filament segment being connected at one end thereof of one of said metal supports, passing around one of said resilient metal supports and connected at the opposite end to another one of said metal supports so as to be positioned above two adjacent electrode structures, said plurality of filament segments being connected in series through said metal supports.

6. The composite fluorescent display tube according to claim 5 wherein at least one auxiliary electrode is provided for said filament at an intermediate point thereof, said auxiliary electrode maintained at a zero reference potential of said display tube so as to decrease apparent difference in the brightness of said display members.

* * * * *

5
10
15
20
25
30
35
40
45
50
55
60
65